

# Compact 5000 I/O and Specialty Modules Specifications

## Catalog Numbers

Digital I/O Modules	5069-IA16, 5069-IB16, 5069-IB16F, 5069-IB16K, 5069-IB6F-3W, 5069-OA16, 5069-OB8, 5069-OB16, 5069-OB16F, 5069-OB16K, 5069-OW4I, 5069-OW16, 5069-OX4I
Analog I/O Modules	5069-IF8, 5069-IY4, 5069-IY4K, 5069-OF4, 5069-OF4K, 5069-OF8
Safety I/O Modules	5069-IB8S, 5069-IB8SK, 5069-OBV8S, 5069-OBV8SK
Specialty Modules	5069-AENTR, 5069-AENTRK, 5069-AEN2TR, 5069-ARM, 5069-FPD, 5069-HSC2XOB4, 5069-SERIAL

Topic	Page
Summary of Changes	2
Power the Compact 5000 I/O Modules	2
Minimum Space Requirements	3
Digital I/O Modules	5
Analog I/O Modules	25
Safety I/O Modules	39
Specialty Modules	49
Additional Resources	63

The Compact 5000™ I/O architecture provides a wide range of input and output modules to span many applications, from high-speed digital to process control. The architecture uses Producer/Consumer technology that allows input information and output status to be shared among multiple Logix 5000® controllers.

Compact 5000 I/O modules are used as local I/O modules in CompactLogix™ 5380 and Compact GuardLogix® 5380 controller systems. The modules are also used as remote I/O modules with CompactLogix 5380, Compact GuardLogix 5380 controllers, and some other Logix 5000 controllers. You use the Studio 5000 Logix Designer® application to configure the modules.

The I/O modules require a removable terminal block (RTB) to connect field-side wiring. RTBs are not included with the I/O modules. You must order RTBs separately.

## Summary of Changes

This publication contains the following new or updated information. This list includes substantive updates only and is not intended to reflect all changes. Change bars identify changes throughout the manual.

Topic	Pages
Updated the high speed counter module catalog number from '5069-HSC2x0B4' to '5069-HSC2X0B4'	Throughout
Added UKEX to the ATEX specifications	Throughout
Removed the EAC certification	Throughout
Updated 5069-0W16 wiring information, functional block diagrams, and MOD power and SA power specifications with Series C information	21
Updated 5069-IF8 supported devices, wiring diagram and information, functional block diagrams, and Inputs and Common mode voltage specifications with Series B information	27
Updated the following module specifications: <ul style="list-style-type: none"> <li>5069-IB8S and 5069-IB8SK - SA power</li> <li>5069-AENTR and 5069-AENTRK - Isolation voltage</li> <li>5069-HSC2X0B4 - Counter input ratings, Isolation voltage</li> </ul>	42 51 59
Updated the SA power and SA power (passthrough), specifications from 'ATEX/IECEX' to 'EX' for the following specialty modules: 5069-AENTR and 5069-AENTRK, 5069-ARM, 5069-FDP	51, 54, 55
Updated the following environmental specification: <ul style="list-style-type: none"> <li>All digital and analog modules - Radiated RF immunity</li> <li>All safety modules - Temperature (operating), Shock (operating), Shock (nonoperating), Radiated RF immunity, Conducted RF immunity</li> <li>All safety and specialty modules - Temperature (operating) tests</li> <li>5069-ARM, 5069-FPD, 5069-HSC2X0B4, 5069- SERIAL modules - Temperature (operating), Radiated RF immunity</li> <li>5069-AENTR and 5069-AENTRK modules - Temperature (operating), Emissions, Radiated RF immunity</li> </ul>	6, 26 39 39, 50 50 50
Removed the following environmental specification for safety modules: Temperature (ambient, max)	39
Updated the following agency certifications: <ul style="list-style-type: none"> <li>All modules<sup>(1)</sup> - UKCA and CE, Ex, IECEX</li> <li>5069-AENTR and 5069-AENTRK modules - RCM, Ex, IECEX</li> <li>5069-SERIAL module - Ex, IECEX</li> <li>5069-AEN2TR module - CE</li> </ul>	5, 25, 39, 49 49 49 53
Added the following agency certifications for all modules <sup>(1)</sup> : Morocco, CCC	5, 25, 39, 49

(1) Applies to all modules except the 5069-AEN2TR module.

## Power the Compact 5000 I/O Modules

There are different types of power that are used with Compact 5000 I/O modules.

Power Type	Description	Related Specifications	
		Name	Description
Module (MOD) Power	System-side power that is used to operate a local or remote system. Power passes across a MOD power bus. Modules draw current from the bus and pass the remaining current to the next module.	MOD power	Level of MOD power current that the module draws from the MOD power bus
		MOD power (passthrough)	Maximum level of MOD power current that the module can pass to the next module.
Sensor Actuator (SA) Power	Field-side power that some modules use to power field-side devices. Power passes across an SA power bus. Some modules draw current from the bus and pass the remaining current to the next module. Other modules do not draw current from the bus but do pass the current to the next module. You use 5069-FPD field potential distributors to establish new SA power buses in a system. <b>IMPORTANT:</b> <ul style="list-style-type: none"> <li>If the system includes DC type modules and AC type modules, you must use a field potential distributor to install them on separate SA power buses.</li> <li>You cannot install AC type modules directly next to a Compact GuardLogix 5380 controller. You must first install a field potential distributor.</li> </ul>	SA power	Level of SA power current that the module draws from the SA power bus
		SA power (passthrough)	Maximum level of SA power current that the module can pass to the next module.
Local Actuator (LA) Power	Field-side power that some Compact 5000 I/O modules use instead of SA power. Modules that use LA power <b>do not use SA power</b> . They only pass SA power to the next I/O module in the system. You must install modules that use LA power on an SA power bus with the same module type. For example, you must install a 5069-0B8 module on an SA power bus that includes DC type modules.	LA power	Maximum level of LA power current that you can apply to the module, by channel, group, or module.

For more information on MOD power, SA power, and LA power, see the user manuals in [Additional Resources on page 63](#).

## Minimum Space Requirements

There are minimum space requirements that are based on whether Compact 5000 I/O modules are installed in a CompactLogix™ 5380, Compact GuardLogix® 5380, CompactLogix 5480 controller system or in a Compact 5000 I/O EtherNet/IP™ adapter system.

**IMPORTANT** If Compact 5000 I/O modules are installed next to a CompactLogix 5380 or Compact GuardLogix 5380, or CompactLogix 5480 controller, you must mount the system horizontally. You can mount CompactLogix 5480 controllers in any orientation if there are no Compact 5000 I/O modules installed next to the controller.

### CompactLogix 5380 or Compact GuardLogix 5380 System Minimum Space Requirements

The minimum distance between all sides of the CompactLogix 5380 system or Compact GuardLogix 5380 system and enclosure walls, wireways, and adjacent equipment varies based on the current operating temperature.

Controllers	Minimum Space at		
	50 °C (122 °F)	55 °C (131 °F)	60 °C (140 °F)
CompactLogix 5380 Standard and Process Controllers	50.8 mm (2.00 in)	50.80 mm (2.00 in)	101.60 mm (4.00 in)
Compact GuardLogix 5380 SIL 2 Controllers			
	Series A catalog numbers	50.8 mm (2.00 in)	101.6 mm (4.00 in)
Series B catalog numbers	50.8 mm (2.00 in)	50.8 mm (2.00 in)	101.6 mm (4.00 in)
Compact GuardLogix 5380 SIL 3 Controllers	50.8 mm (2.00 in)	50.8 mm (2.00 in)	101.6 mm (4.00 in)

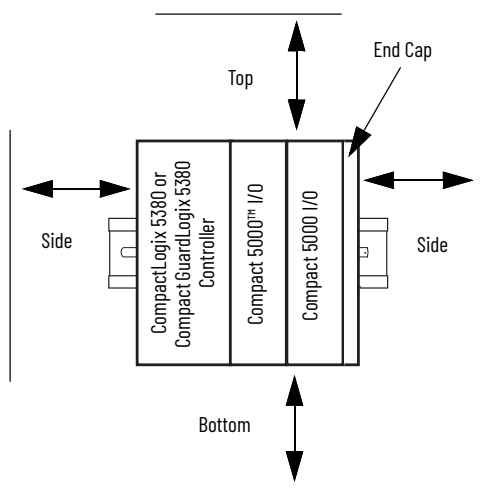

For more information on how to install a CompactLogix 5380 controller system, see the CompactLogix 5380 Controllers Installation Instructions, publication [5069-IN013](#).

For more information on how to install a Compact GuardLogix 5380 controller system, see the Compact GuardLogix 5380 SIL 2 Controllers Installation Instructions, publication [5069-IN014](#).

### CompactLogix 5480 System Minimum Space Requirements

The minimum distance for a system that includes only a CompactLogix 5480 controller is as follows:

- 25.00 mm (0.98 in.) between the sides of the controller and the cabinet
- 25.00 mm (0.98 in.) between the front of the controller and the cabinet
- 50.00 mm (1.96 in.) between the top and bottom of the controller and the cabinet

We recommend that you install the controller near the bottom of the enclosure, where the ambient temperature is lower.

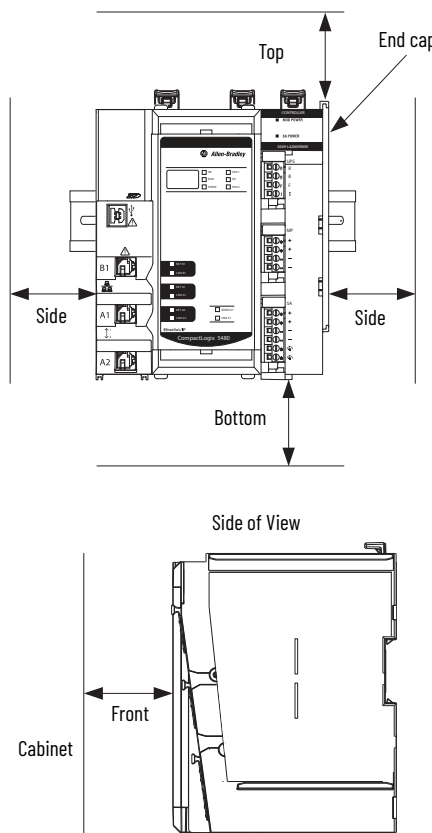

For more information on how to install a CompactLogix 5480 controller system, see the CompactLogix 5480 Controllers Installation Instructions, publication [5069-IN019](#).

## Adapter Minimum Space Requirements

The minimum distance on all sides of the adapter system is as follows:

- 25.40 mm (1.00 in) - If the system uses only Compact 5000 I/O standard modules.
- 50.80 mm (2.00 in) - If the system uses at least one Compact 5000 I/O safety module.

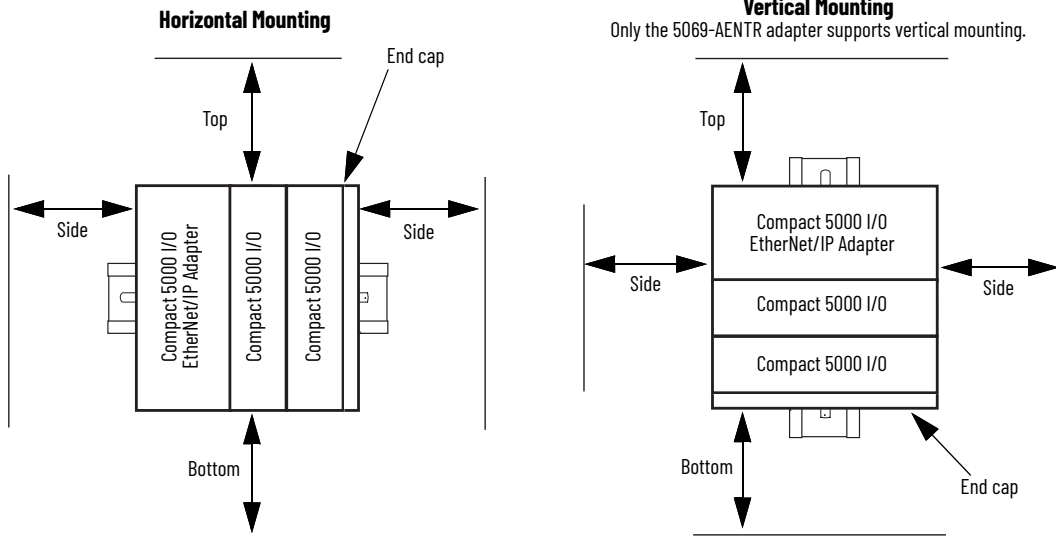

For more information on how to install a Compact 5000 I/O EtherNet/IP adapter system, see the Compact 5000 I/O EtherNet/IP Adapters Installation Instructions, publication [5069-IN003](#).

## Digital I/O Modules

The following digital I/O modules are available.

I/O Type	Cat. No.	Description	Page
AC digital input	5069-IA16	16-point 120/240V AC input module	7
DC digital input	5069-IB16	16-point sinking input module	9
	5069-IB16K	16-point, conformal-coated sinking input module	
	5069-IB16F	16-point, sinking fast input module	11
	5069-IB6F-3W	3-wire, sinking fast input module	
AC digital output	5069-OA16	16-point 120/240V AC output module	13
DC digital output	5069-OB8	8-point 24V DC output module	15
	5069-OB16	16-point, sourcing, high-current output module	17
	5069-OB16K	16-point, conformal-coated sourcing output module	
	5069-OB16F	16-point, sourcing fast output module	
Relay output	5069-OW4I	4-point, isolated, normally-open relay output module	19
	5069-OW16	16-point, normally-open relay output module	21
	5069-OX4I	4-point, isolated, normally-open/normally-closed relay output module	23

### Certifications - Digital I/O Modules

Certification <sup>(1)</sup>	5069-IA16, 5069-IB16, 5069-IB16K, 5069-IB16F, 5069-IB6F-3W, 5069-OA16, 5069-OB8, 5069-OB16, 5069-OB16K, 5069-OB16F	5069-OW4I, 5069-OW16, 5069-OX4I
c-UL-us	UL Listed Industrial Control Equipment, certified for US and Canada. See UL File E65584. UL Listed for Class I, Division 2 Group A,B,C,D Hazardous Locations, certified for U.S. and Canada. See UL File E194810.	
UKCA and CE	UK Statutory Instrument 2016 No. 1091 and European Union 2014/30/EU EMC Directive, compliant with: EN 61326-1; Meas./Control/Lab., Industrial Requirements EN 61000-6-2; Industrial Immunity EN 61000-6-4; Industrial Emissions EN 61131-2; Programmable Controllers (Clause 8, Zone A & B)  UK Statutory Instrument 2016 No. 1101 and European Union 2014/35/EU LVD, compliant with: EN 61010-2-201; Control Equipment Safety Requirements  UK Statutory Instrument 2012 No. 3032 and European Union 2011/65/EU RoHS, compliant with: EN IEC 63000; Technical documentation	
RCM	Australian Radiocommunications Act, compliant with: EN 61000-6-4; Industrial Emissions	
Ex	UK Statutory Instrument 2016 No. 1107 and European Union 2014/34/EU ATEX Directive, compliant with:  EN IEC 60079-0; General Requirements EN IEC 60079-7; Explosive Atmospheres, Protection "e" II 3 G Ex ec IIC T4 Gc DEMKO 15 ATEX 1484X and UL22UKEX2379X  EN IEC 60079-0; General Requirements EN IEC 60079-7; Explosive Atmospheres, Protection "e" EN IEC 60079-15; Potentially Explosive Atmospheres, Protection "n" II 3 G Ex ec nC IIC T4 Gc DEMKO 15 ATEX 1484X and UL 22UKEX2379X When used at or below 125V DC or 30V DC	
IECEx	IECEx System, compliant with:  IEC 60079-0; General Requirements IEC 60079-7; Explosive Atmospheres, Protection "e" II 3 G Ex ec IIC T4 Gc IECEx UL 15.0055X  IEC 60079-0; General Requirements IEC 60079-7; Explosive Atmospheres, Protection "e" IEC 60079-15; Potentially Explosive Atmospheres, Protection "n" II 3 G Ex ec nC IIC T4 Gc IECEx UL 15.0055X When used at or below 125V DC or 30V DC	
KC	Korean Registration of Broadcasting and Communications Equipment, compliant with: Article 58-2 of Radio Waves Act, Clause 3	
Morocco	Arrêté ministériel n° 6404-15 du 1er muharram 1437 Arrêté ministériel n° 6404-15 du 29 ramadan 1436	
CCC	CNCA-C23-01:2019 强制性产品认证实施规则 防爆电气 CNCA-C23-01:2019 CCC Implementation Rule Explosion-Proof Electrical Products CCC: 2020312309000308	

(1) See the Product Certification link at [rok.auto/certifications](http://rok.auto/certifications) for Declarations of Conformity, Certificates, and other certification details.

Environmental Specifications - Digital I/O Modules

Attribute	5069-1A16, 5069-0A16, 5069-0B8, 5069-0W16	5069-0W4I, 5069-0X4I	5069-1B16, 5069-1B16K, 5069-1B16F, 5069-1B6F-3W, 5069-0B16, 5069-0B16K, 5069-0B16F
Temperature, operating IEC 60068-2-1 (Test Ad, Operating Cold) IEC 60068-2-2 (Test Bd, Operating Dry Heat) IEC 60068-2-14 (Test Nb, Operating Thermal Shock)	0...60 °C (32...140 °F)		
Temperature, surrounding air, max	60 °C (140 °F)		
Temperature, nonoperating IEC 60068-2-1 (Test Ab, Unpackaged Nonoperating Cold) IEC 60068-2-2 (Test Bb, Unpackaged Nonoperating Dry Heat) IEC 60068-2-14 (Test Na, Unpackaged Nonoperating Thermal Shock)	-40...+85 °C (-40...+185 °F)		
Relative humidity IEC 60068-2-30 (Test Db, Unpackaged Damp Heat)	5...95% noncondensing		
Vibration IEC 60068-2-6 (Test Fc, Operating)	5 g @ 10...500 Hz		
Shock, operating IEC 60068-2-27 (Test Ea, Unpackaged Shock)	30 g		
Shock, nonoperating IEC 60068-2-27 (Test Ea, Unpackaged Shock)	50 g		
Emissions	IEC 61000-6-4		
ESD immunity IEC 61000-4-2	6 kV contact discharges 8 kV air discharges		
Radiated RF immunity IEC 61000-4-3	10V/m with 1 kHz sine wave 80% AM from 80...6000 MHz		
EFT/B immunity IEC 61000-4-4	±4 kV @ 5 kHz on power ports ±4 kV @ 5 kHz on signal ports	±4 kV @ 5 kHz on power ports ±3 kV @ 5 kHz on input ports	
Surge transient immunity IEC 61000-4-5	±1 kV line-line (DM) and ±2 kV line-earth (CM) on power ports ±1 kV line-line (DM) and ±2 kV line-earth (CM) on signal ports		
Conducted RF immunity IEC 61000-4-6	10V rms with 1 kHz sine wave 80% AM from 150 kHz...80 MHz		
Voltage variation IEC 61000-4-29	—	10 ms interruption on MOD power port	
Corrosion resistance classification	ISA S71.04 G2	—	
North American temp code	T4		
UKEX/ATEX temp code	T4		
IECEX temp code	T4		
Enclosure type	None (open-style)		

# 5069-IA16

## Digital 16-point 120/240V AC Input Module

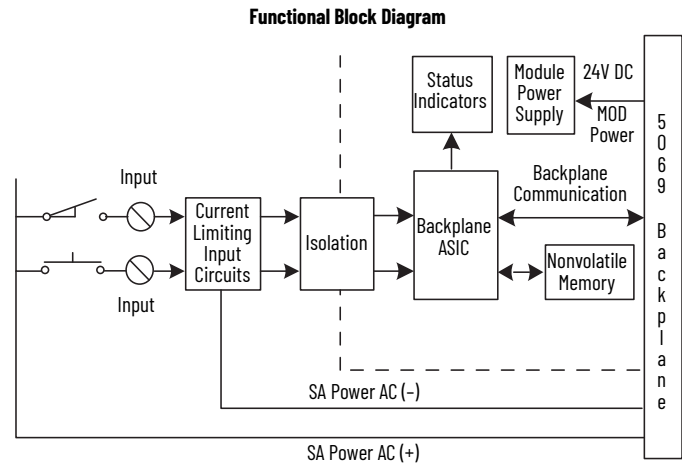
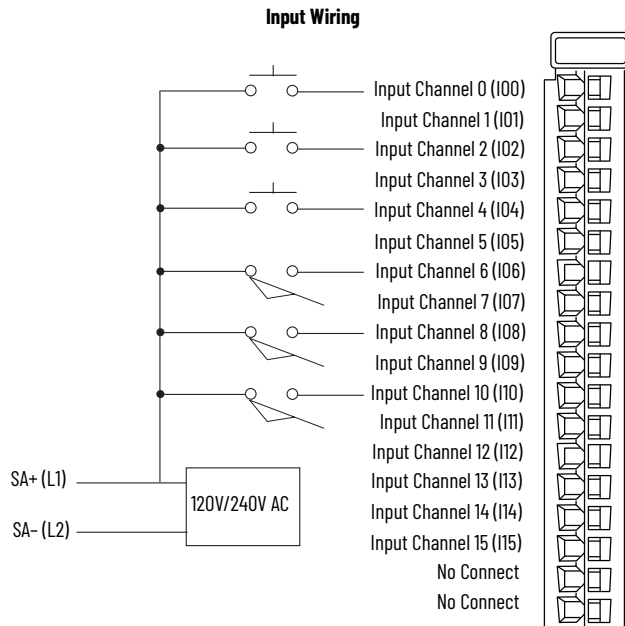

### Technical Specifications - 5069-IA16

Attribute	5069-IA16
Number of inputs	16 (One group of 16)
Voltage category	120/240V AC
Voltage and current ratings	
Input voltage range	79...264V AC
Input voltage frequency	47...63 Hz
MOD power	75 mA @ 18...32V DC
MOD power (passthrough) <sup>(1)</sup>	9.55 A @ 18...32V DC
SA power	240 mA @ 79...264V AC
SA power (passthrough) <sup>(1)</sup>	9.975 A @ 79...264V AC
Do not exceed 10 A MOD or SA power (passthrough) current draw. The 5069-IA16 module complies to UKEX/ATEX/IECEx when used at or below 125V AC.	
Power dissipation, max	3.5 W
Thermal dissipation, max	11.9 BTU/hr
Isolation voltage	250V (continuous), Basic Insulation Type Type tested at 1800V AC for 60 s No isolation between individual channels
Module keying	Electronic keying via programming software
Indicators	1 green/red module status indicator 16 yellow/red I/O status indicators
Slot width	1
Dimensions (HxWxD)	144.57 x 22 x 105.42 mm (5.69 x 0.87 x 4.15 in.)
DIN rail	Compatible zinc-plated chromate-passivated steel DIN rail. You can use the EN50022 - 35 x 7.5 mm (1.38 x 0.30 in.) DIN rail.
RTB	One of these RTB types. • 5069-RTB18-SPRING RTB • 5069-RTB18-SCREW RTB <b>IMPORTANT:</b> You must order RTBs separately. RTBs do not ship with Compact 5000™ I/O modules. We recommend that you order only the RTB type that your system requires.
RTB torque (5069-RTB18-SCREW RTB only)	0.4 N·m (3.5 lb·in)
RTB keying	None

<b>Channel Connections</b>	The diagram shows devices that are connected to channels 0, 2, 4, 6, 8, and 10. You are not restricted to using only those channels. You can connect devices to any channel or combination of channels as needed.
<b>SA Power</b>	Connections to an external power supply that provides SA power via the SA power RTB on one of the following: <ul style="list-style-type: none"> <li>• CompactLogix 5380 controller</li> <li>• CompactLogix 5480 controller</li> <li>• 5069-AENTR or 5069-AEN2TR EtherNet/IP adapter</li> <li>• 5069-FPD field potential distributor</li> </ul>

- IMPORTANT**  
Remember the following:
- The 5069-IA16 module uses AC SA power. You must connect AC power to the component, that is, the controller, adapter, or field potential distributor that provides SA power to the module.
  - If you install a 5069-IA16 module as a local I/O module in a Compact GuardLogix 5380 controller system, you must install a field potential distributor that has AC power connected to it and install the 5069-IA16 module next to the field potential distributor.
  - You can't install modules that draw AC SA power next to a Compact GuardLogix 5380 controller. Compact GuardLogix 5380 controllers do not support AC power on their SA power RTBs.
  - The 5069-IA16 module inputs use a shared common. The inputs have a return through internal module circuitry to the SA (-) terminal on the SA power RTB. For more information, see [page 2](#).
  - If you install modules in a Compact 5000 I/O system that use AC SA power and DC SA power, you must install them on separate SA power buses.
  - You use the 5069-FPD field potential distributor to establish a new SA power bus in a Compact 5000 I/O system. SA power buses are isolated from each other. To keep the modules on separate SA power buses, complete the following steps.
    1. Install the modules that use one type of SA power, for example AC, to the right of the adapter or controller, that is, the first SA power bus.
    2. Install the 5069-FPD field potential distributor to establish a second SA power bus.
    3. Install the modules that use the other type of SA power, for example DC, on the second SA power bus.

### Technical Specifications - 5069-IA16

Attribute	5069-IA16
Wire category	2 - input ports 2 - power ports 1 wire per terminal for each signal port
Wire size	
5069-RTB18-SPRING RTB	0.5...1.5 mm <sup>2</sup> (22...16 AWG) solid or stranded shielded copper wire rated at 105 °C (221 °F), or greater, 2.9 mm (0.11 in.) max diameter including insulation, single wire connection only.
5069-RTB18-SCREW RTB	0.5...1.5 mm <sup>2</sup> (22...16 AWG) solid or stranded shielded copper wire rated at 105 °C (221 °F), or greater, 3.5 mm (0.14 in.) max diameter including insulation, single wire connection only.
Insulation-stripping length	
5069-RTB18-SPRING RTB	10 mm (0.39 in.)
5069-RTB18-SCREW RTB	12 mm (0.47 in.)
Weight, approx	175 g (0.39 lb)
IEC Input Compatibility	Type 1
On-state voltage, min	79V AC
On-state voltage, nom	120/240V AC
On-state voltage, max	264V AC
Off-state voltage, max	40V AC
Input current per channel, max	15 mA @ 264V AC
On-state current, min	2 mA @ 79V AC 3 mA @ 164V AC
On-state current, nom	5 mA @ 120V AC/50 Hz 6 mA @ 120V AC/60 Hz 9 mA @ 240V AC/50 Hz 11 mA @ 240V AC/60 Hz
On-state current, max	15 mA @ 264V AC
Off-state current, max	2 mA

### Technical Specifications - 5069-IA16

Attribute	5069-IA16
Input impedance, nom	24 kΩ @ 120V AC/50 Hz 20 kΩ @ 120V AC/60 Hz 27 kΩ @ 240V AC/50 Hz 22 kΩ @ 240V AC/60 Hz
Input impedance, min	17.6 kΩ @ 264V AC/63 Hz
Inrush current, max	600 mA
Input delay time	
Off to On	10 ms (typ) @ 0...60 °C (32...140 °F)
On to Off	10 ms (typ) @ 0...60 °C (32...140 °F)
Input filter times	
Off to On	Hardware delay: 10 ms (typ) + filter time User-selectable filter times: 120V AC input - 1 ms 240V AC input - 1 ms, 2 ms, 5 ms
On to Off	Hardware delay: 10 ms (typ) + filter time User-selectable filter times: 120V AC input - 10 ms, 20 ms 240V AC input - 5 ms, 10 ms, 20 ms

With the 5069-IA16 module, the Logix Designer application lets you choose multiple filter values, including values that are invalid for some input signals. For example, the only valid Off to On filter value when a 120V AC signal is connected to the module is 1 ms. However, you can choose 1 ms, 2 ms, or 5 ms. If you select an invalid input filter value, the module can read signal levels incorrectly. For more information, see the Compact 5000 I/O Digital Modules User Manual, publication [5069-UM004](#).

- (1) Level of Mod or SA power current that passes through the module depends on the system configuration, such as, module slot location and the other module types that are used in the system. For more information, see the controller user manuals in [Additional Resources on page 63](#).

For **Certifications**, see [page 5](#).

For **Environmental Specifications**, see [page 6](#).



# 5069-IB16, 5069-IB16K, 5069-IB16F

## Digital 16-point Sinking Input Modules

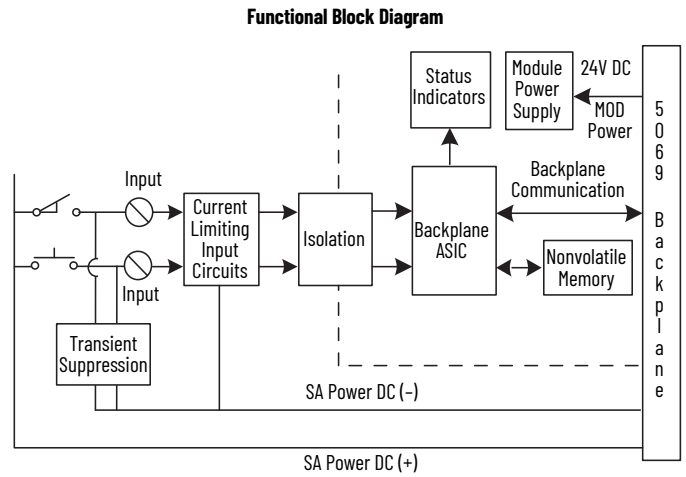
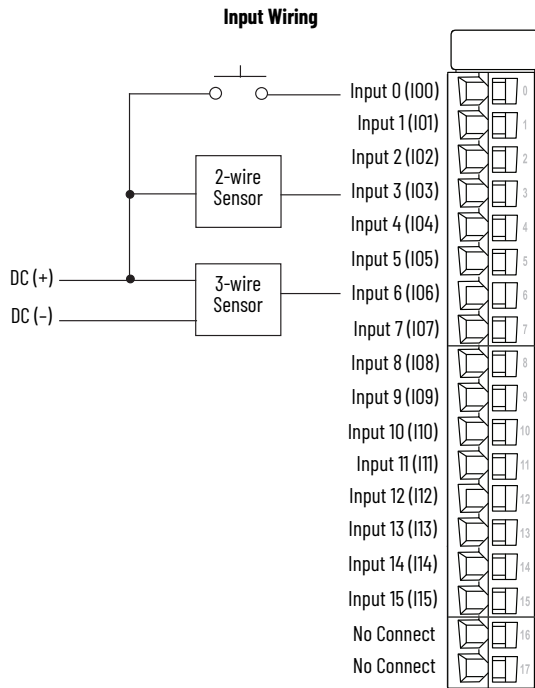

<b>Channel Connections</b>	The diagram shows devices that are connected to channels 0, 3, and 6. You are not restricted to use only those channels. You can connect devices to any channel or combination of channels as needed.
<b>SA Power</b>	Connections to an external power supply that provides SA power are made via the SA power RTB on one of the following: <ul style="list-style-type: none"> <li>• CompactLogix 5380 controller</li> <li>• Compact GuardLogix 5380 controller</li> <li>• CompactLogix 5480 controller</li> <li>• 5069-AENTR or 5069-AEN2TR EtherNet/IP Adapter</li> <li>• 5069-FPD field potential distributor</li> </ul>

- IMPORTANT**  
Remember the following:
- The 5069-IB16, 5069-IB16K, and 5069-IB16F modules use DC SA power. You must connect DC power to the component, that is, the controller, adapter, or field potential distributor that provides SA power to the modules.
  - The 5069-IB16 and 5069-IB16F module inputs use a shared common. The inputs have a return through internal module circuitry to the SA (-) terminal on the SA power RTB. For more information, see [page 2](#).
  - If you install modules in a Compact 5000 I/O system that use AC SA power and DC SA power, you must install them on separate SA power buses.
  - You use the 5069-FPD field potential distributor to establish a new SA power bus in a Compact 5000 I/O system. SA power buses are isolated from each other. To keep the modules on separate SA power buses, complete the following steps.
    1. Install the modules that use one type of SA power, for example AC, to the right of the adapter or controller, that is, the first SA power bus.
    2. Install the 5069-FPD field potential distributor to establish a second SA power bus.
    3. Install the modules that use the other type of SA power, for example DC, on the second SA power bus.

### Technical Specifications - 5069-IB16, 5069-IB16K, and 5069-IB16F

Attribute	5069-IB16, 5069-IB16K	5069-IB16F
Inputs	16 Channels (1 group of 16), sinking	
Voltage category	12/24V DC Sink	
Voltage and current ratings		
Input ratings	4...7.4 mA per channel @ 10...32V DC	
MOD power	75 mA @ 18...32V DC	
MOD power (passthrough) <sup>(1)</sup>	9.55 A @ 18...32V DC	
SA power	200 mA @ 10...32V DC	
SA power (passthrough) <sup>(1)</sup>	9.95 A @ 10...32V DC	
Power dissipation, max	3.9 W	
Thermal dissipation, max	13.3 BTU/hr	
Isolation voltage	250V (continuous), Basic Insulation Type No isolation between SA power and input ports No isolation between individual input ports	
Module keying	Electronic keying via programming software	
Indicators	1 green/red module status indicator 16 yellow/red I/O status indicators	
Slot width	1	
Dimensions (HxWxD), approx	144.57 x 22 x 105.42 mm (5.69 x 0.87 x 4.15 in.)	
DIN rail	Compatible zinc-plated chromate-passivated steel DIN rail. You can use the EN50022 - 35 x 7.5 mm (1.38 x 0.30 in.) DIN rail.	
RTB	One of these RTB types. <ul style="list-style-type: none"> <li>• 5069-RTB18-SPRING RTB</li> <li>• 5069-RTB18-SCREW RTB</li> </ul> <b>IMPORTANT:</b> You must order RTBs separately. RTBs do not ship with Compact 5000 I/O modules. We recommend that you order only the RTB type that your system requires.	
RTB torque (5069-RTB18-SCREW RTB only)	0.4 N-m (3.5 lb-in)	
RTB keying	None	

**Technical Specifications - 5069-IB16, 5069-IB16K, and 5069-IB16F**

Attribute	5069-IB16, 5069-IB16K	5069-IB16F
Wire category <sup>(2)</sup>	2 - input ports 2 - power ports 1 wire per terminal for each signal port	
Wire size		
5069-RTB18-SPRING RTB	0.5...1.5 mm <sup>2</sup> (22...16 AWG) solid or stranded shielded copper wire rated at 105 °C (221 °F), or greater, 2.9 mm (0.11 in.) max diameter including insulation, single wire connection only.	
5069-RTB18-SCREW RTB	0.5...1.5 mm <sup>2</sup> (22...16 AWG) solid or stranded shielded copper wire rated at 105 °C (221 °F), or greater, 3.5 mm (0.14 in.) max diameter including insulation, single wire connection only.	
Insulation-stripping length	5069-RTB18-SPRING RTB: 10 mm (0.39 in.) 5069-RTB18-SCREW RTB: 12 mm (0.47 in.)	
Weight, approx	175 g (0.39 lb)	
On-state voltage, min	10V DC	
On-state voltage, nom	24V DC	
On-state voltage, max	32V DC	
On-state current, min	4 mA @ 10V	
On-state current, nom	6 mA @ 24V DC	
On-state current, max	7.4 mA @ 32V DC	
Off-state voltage, max	5V DC	
Off-state current, max	1.5 mA	
Input impedance, min	1.33 kΩ	
Input impedance, nom	4.1 kΩ	
Input impedance, max	7.0 kΩ	
Inrush current, max	< 250 mA peak (decaying to, 37% in 22 ms, without activation)	
Input delay time (screw to backplane)		
Off to On	≤ 100 μs, ±10 μs @ 25 °C (77 °F)	≤ 10 μs, ±1 μs @ 25 °C (77 °F)
On to Off	≤ 100 μs, ±10 μs @ 25 °C (77 °F)	≤ 10 μs, ±1 μs @ 25 °C (77 °F)
Input drift over temperature span	±100 ns/°C (55.6 ns/°F) from 0...60 °C (32...140 °F)	< 10 ns/°C (5.56 ns/°F) from 0...60 °C (32...140 °F)
Input On to Off minimum pulse width	60 μs	6 μs
Input Off to On minimum pulse width	60 μs	6 μs

**Technical Specifications - 5069-IB16, 5069-IB16K, and 5069-IB16F**

Attribute	5069-IB16, 5069-IB16K	5069-IB16F
Input filter time		
Off to On	Hardware delay: 50 μs + filter time User-selectable filter time: 0...50 ms	Hardware delay: 2 μs + filter time User-selectable filter time: 0...50 ms
On to Off	Hardware delay: 50 μs + filter time User-selectable filter time: 0...50 ms	Hardware delay: 3 μs + filter time User-selectable filter time: 0...50 ms
Reverse polarity protection	Yes	
Overvoltage protection, max	36V (fuse protected)	
Pulse and period measurements	Not supported	±2 μs
Counter frequency	0 - f <sub>max</sub> = 500 Hz (Inv period 2 ms)	0 - f <sub>max</sub> = 30 kHz (Inv period 33.3 μs)
Frequency counter	0 - f <sub>max</sub> = 500 Hz (Inv period 2 ms)	0 - f <sub>max</sub> = 30 kHz (Inv period 33.3 μs)
Time stamp of inputs	Not supported	±10 μs accuracy 1 ns resolution
Overrides	Not supported	
Pulse latching	Not supported	Supported
Events	Not supported	4 events supported (triggered by any input or simple counters)
Pattern matching	Not supported	Supported
Extended counters	Not supported	

- (1) Level of Mod or SA power current that passes through the module depends on the system configuration, such as, module slot location and the other module types that are used in the system. For more information, see the controller user manuals in [Additional Resources on page 63](#).
- (2) Use this Conductor Category information to plan conductor routes. See the Industrial Automation Wiring and Grounding Guidelines, publication [1770-4.1](#).

For **Certifications**, see [page 5](#).  
For **Environmental Specifications**, see [page 6](#).

# 5069-IB6F-3W

## Digital 3-wire Sinking Input Module

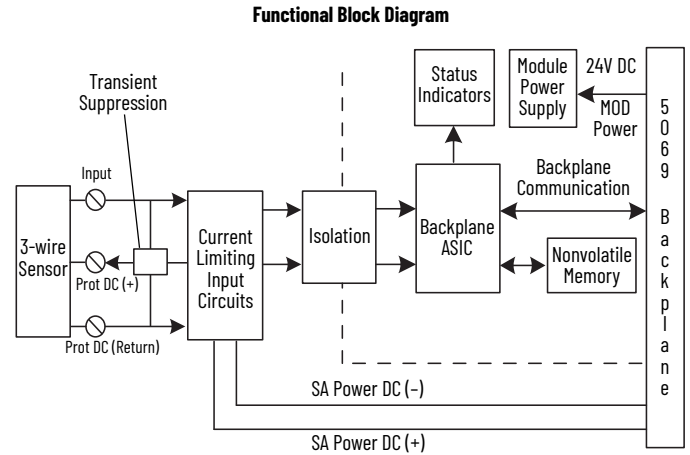
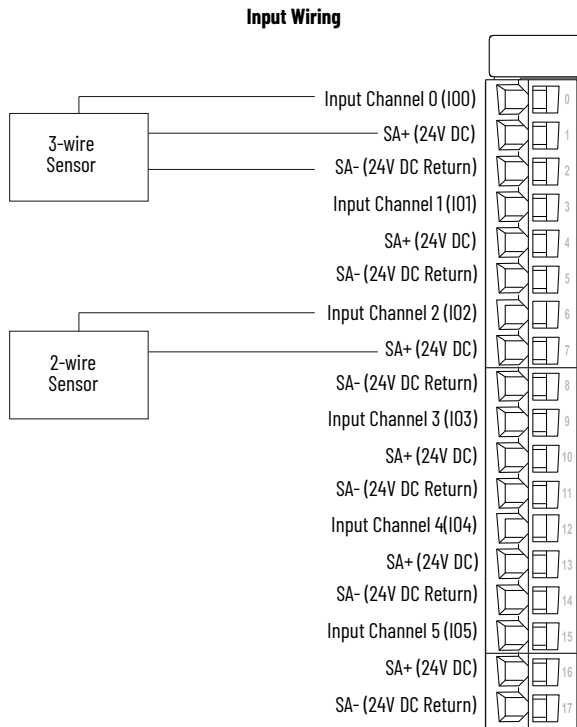

### Technical Specifications - 5069-IB6F-3W

Attribute	5069-IB6F-3W
Inputs	6 Channels (1 group of 6), sinking
Voltage category	12/24V DC Sink
Voltage and current ratings	
Input ratings	4...7.4 mA per channel @ 10...32V DC
Output supply ratings	150 mA per channel @ 10...32V DC 900 mA per module @ 10...32V DC
MOD power	75 mA @ 18V...32V DC
MOD power (passthrough) <sup>(1)</sup>	9.55 A @ 18...32V DC
SA power	900 mA @ 10...32V DC
SA power (passthrough) <sup>(1)</sup>	9.95 A @ 10...32V DC
Do not exceed 10 A MOD or SA power (passthrough) current draw.	
Power dissipation, max	2.4 W
Thermal dissipation, max	8.1 BTU/hr
Isolation voltage	250V (continuous), Basic Insulation Type No isolation between SA power and input ports No isolation between individual input ports
Module keying	Electronic, module keying, software configurable
Indicators	1 green/red module status indicator 6 yellow/red I/O status indicators
Slot width	1
Dimensions (HxWxD), approx	144.57 x 22 x 105.42 mm (5.69 x 0.87 x 4.15 in.)
DIN rail	Compatible zinc-plated chromate-passivated steel DIN rail. You can use the EN50022 - 35 x 7.5 mm (1.38 x 0.30 in.) DIN rail.
RTB	One of these RTB types. • 5069-RTB18-SPRING RTB • 5069-RTB18-SCREW RTB <b>IMPORTANT:</b> You must order RTBs separately. RTBs do not ship with Compact 5000 I/O modules. We recommend that you order only the RTB type that your system requires.
RTB torque (5069-RTB18-SCREW RTB only)	0.4 N•m (3.5 lb•in)
RTB keying	None

<b>Channel Connections</b>	The diagram shows devices that are connected to channels 0 and 2. You are not restricted to using only those channels. You can connect devices to any channel or combination of channels as needed.
<b>SA Power</b>	Connections to an external power supply that provides SA power are made via the SA power RTB on one of the following: <ul style="list-style-type: none"> <li>• CompactLogix 5380 controller</li> <li>• Compact GuardLogix 5380 controller</li> <li>• CompactLogix 5480 controller</li> <li>• 5069-AENTR or 5069-AEN2TR EtherNet/IP Adapter</li> <li>• 5069-FPD field potential distributor</li> </ul>

- IMPORTANT**  
Remember the following:
- The 5069-IB6F-3W module uses DC SA power. You must connect DC power to the component, that is, the controller, adapter, or field potential distributor that provides SA power to the module.
  - If you install modules in a system that use AC SA power and DC SA power, you must install them on separate SA power buses.
  - You use a 5069-FPD field potential distributor to establish a new SA power bus in a system. SA power buses are isolated from each other. To keep the modules on separate SA power buses, complete these steps.
    1. Install the modules that use one type of SA power, for example DC, to the right of the adapter or controller, that is, the first SA power bus.
    2. Install the 5069-FPD field potential distributor to establish a second SA power bus.
    3. Install the modules that use the other type of SA power, for example AC, on the second SA power bus.

**Technical Specifications - 5069-IB6F-3W**

Attribute	5069-IB6F-3W
Wire category <sup>(2)</sup>	2 - input ports 2 - power ports 1 wire per terminal for each signal port
Wire size	
5069-RTB18-SPRING RTB	0.5...1.5 mm <sup>2</sup> (22...16 AWG) solid or stranded copper wire rated at 105 °C (221 °F), or greater, 2.9 mm (0.11 in.) max diameter including insulation, single wire connection only.
5069-RTB18-SCREW RTB	0.5...1.5 mm <sup>2</sup> (22...16 AWG) solid or stranded copper wire rated at 105 °C (221 °F), or greater, 3.5 mm (0.14 in.) max diameter including insulation, single wire connection only.
Insulation-stripping length	
5069-RTB18-SPRING RTB	10 mm (0.39 in.)
5069-RTB18-SCREW RTB	12 mm (0.47 in.)
Weight, approx	175 g (0.39 lb)
On-state voltage, min	10V DC
On-state voltage, nom	24V DC
On-state voltage, max	32V DC
Off-state voltage, max	5V DC
On-state current, min	4 mA @ 10V DC
On-state current, nom	6 mA @ 24V DC
On-state current, max	7.4 mA @ 32V DC
Off-state current, max	1.5 mA
Input impedance, nom	4.1 kΩ
Input impedance, max	7.0 kΩ
Inrush current, max	< 250 mA peak (decaying to, 37% in 22 ms, without activation)
Input delay time (screw to backplane)	
Off to On	≤ 10 μs, ±1 μs @ 25 °C (77 °F)
On to Off	≤ 10 μs, ±1 μs @ 25 °C (77 °F)
Input drift over temperature span	±10 ns/°C (5.56 ns/°F) from 0...60 °C (32...140 °F)
Input On to Off minimum pulse width	6 μs
Input Off to On minimum pulse width	6 μs

**Technical Specifications - 5069-IB6F-3W**

Attribute	5069-IB6F-3W
Input filter time	
Off to On	Hardware delay: 2 μs + filter time User-selectable filter time: 0...50 ms
On to Off	Hardware delay: 3 μs + filter time User-selectable filter time: 0...50 ms
Reverse polarity protection	Yes
Overvoltage protection, max	36V (fuse protected)
Pulse width and period measurements	±2 μs
Simple counters Counter frequency	0 - f <sub>max</sub> = 30 kHz (Inv period 33.3 μs)
Frequency counter	0 - f <sub>max</sub> = 30 kHz (Inv period 33.3 μs)
Time stamp of inputs	±10 μs accuracy 1 ns resolution
Overrides	Not supported
Pulse latching	Supported
Events	4 events supported (triggered by any input or simple counters)
Pattern matching	Supported
Extended counters	Not supported

- (1) Level of Mod or SA power current that passes through the module depends on the system configuration, such as, module slot location and the other module types that are used in the system. For more information, see the controller user manuals in [Additional Resources on page 63](#).
- (2) Use this Conductor Category information to plan conductor routes. See the Industrial Automation Wiring and Grounding Guidelines, publication [1770-4.1](#).

For **Certifications**, see [page 5](#).

For **Environmental Specifications**, see [page 6](#).

# 5069-0A16

## Digital 16-point 120/240V AC Output Module

Output Wiring

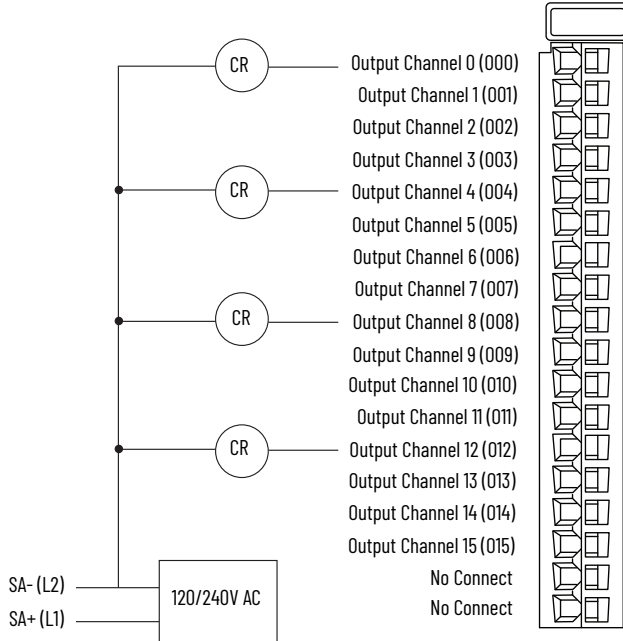

Functional Block Diagram

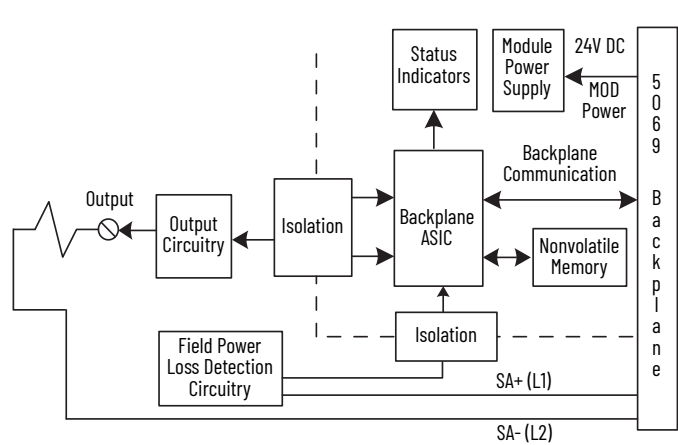

### Technical Specifications - 5069-0A16

Attribute	5069-0A16
Number of outputs	16 (One group of 16)
Voltage category	120/240V AC
Voltage and current ratings	
Output voltage range	85...264V AC
Output voltage frequency	47...63 Hz
MOD power	100 mA @ 18...32V DC
MOD power (passthrough) <sup>(1)</sup>	9.55 A @ 18...32V DC
SA power	4 A @ 85...264V AC
SA power (passthrough) <sup>(1)</sup>	9.975 A @ 85...264V AC
Do not exceed 10 A MOD or SA power (passthrough) current draw. The 5069-0A16 module complies to ULEX/ATEX/IECEx when used at or below 125V AC.	
Power dissipation, max	3.4 W
Thermal dissipation, max	11.6 BTU/hr
Isolation voltage	250V (continuous), Basic Insulation Type Type tested at 1800V AC for 60 s No isolation between individual channels
Module keying	Electronic keying via programming software
Indicators	1 green/red module status indicator 16 yellow/red I/O status indicators
Slot width	1
Dimensions (HxWxD), approx	144.57 x 22 x 105.42 mm (5.69 x 0.87 x 4.15 in.)
DIN rail	Compatible zinc-plated chromate-passivated steel You can use the EN50022 - 35 x 7.5 mm (1.38 x 0.30 in.) DIN rail.
RTB	One of these RTB types. • 5069-RTB18-SPRING RTB • 5069-RTB18-SCREW RTB <b>IMPORTANT:</b> You must order RTBs separately. RTBs do not ship with Compact 5000 I/O modules. We recommend that you order only the RTB type that your system requires.
RTB torque (5069-RTB18-SCREW RTB only)	0.4 N·m (3.5 lb-in)
RTB keying	None

<b>Channel Connections</b>	The diagram shows devices that are connected to channels 0, 4, 8, and 12. You are not restricted to using only those channels. You can connect devices to any channel or combination of channels as needed.
<b>SA Power</b>	Connections to an external power supply that provides SA power via the SA power RTB on one of the following: <ul style="list-style-type: none"> <li>CompactLogix 5380 controller</li> <li>CompactLogix 5480 controller</li> <li>5069-AENR or 5069-AEN2R EtherNet/IP adapter</li> <li>5069-FPD field potential distributor</li> </ul>

- IMPORTANT**  
Remember the following:
- The 5069-0A16 module uses AC SA power. You must connect AC power to the component, that is, the CompactLogix 5380 controller, adapter, or field potential distributor that provides SA power to the module.
  - If you install a 5069-0A16 module as a local I/O module in a Compact GuardLogix 5380 controller system, you must install a field potential distributor that has AC power connected to it and install the 5069-0A16 module next to it.
  - You cannot install modules that draw AC SA power next to a Compact GuardLogix 5380 controller. Compact GuardLogix 5380 controllers do not support AC power on their SA power RTBs.
  - The 5069-0A16 module outputs use a shared common. The outputs have a return through internal module circuitry to the SA (-) terminal on the SA power RTB. For more information, see page 6.
  - If you install modules in a Compact 5000 I/O system that use AC SA power and DC SA power, you must install them on separate SA power buses.
  - You use the 5069-FPD field potential distributor to establish a new SA power bus in a Compact 5000 I/O system. SA power buses are isolated from each other. To keep the modules on separate SA power buses, complete the following steps.
    - Install the modules that use one type of SA power, for example AC, to the right of the adapter or controller, that is, the first SA power bus.
    - Install the 5069-FPD field potential distributor to establish a second SA power bus.
    - Install the modules that use the other type of SA power, for example DC, on the second SA power bus.

**Technical Specifications - 5069-0A16**

Attribute	5069-0A16
Wire category	2 - output ports 2 - power ports 1 wire per terminal for each signal port
Wire size	
5069-RTB18-SCREW RTB	0.5...1.5 mm <sup>2</sup> (22...16 AWG) solid or stranded shielded copper wire rated at 105 °C (221 °F), or greater, 3.5 mm (0.14 in.) max diameter including insulation, single wire connection only.
5069-RTB18-SPRING RTB	0.5...1.5 mm <sup>2</sup> (22...16 AWG) solid or stranded shielded copper wire rated at 105 °C (221 °F), or greater, 2.9 mm (0.11 in.) max diameter including insulation, single wire connection only.
Insulation-stripping length	
5069-RTB18-SPRING RTB	10 mm (0.39 in.)
5069-RTB18-SCREW RTB	12 mm (0.47 in.)
Weight, approx	175 g (0.39 lb)
On-state voltage, min	85V AC
On-state voltage, nom	120/240V AC
On-state voltage, max	264V AC
On-state voltage drop, max	1.5V AC @ 0.5 A
Output current per channel, max	0.5 A
Output current per module, max	4 A
Off-state leakage current, max <sup>(2)</sup>	1 mA
Surge current per point	5 A max for 25 ms per point, repeatable every 2 s
Output delay time (backplane to screw)	
Off to On	1/2 cycle time (typ) @ 0...60 °C (32...140 °F)
On to Off	1/2 cycle time (typ) @ 0...60 °C (32...140 °F)
Field power loss detection	Yes

**Technical Specifications - 5069-0A16**

Attribute	5069-0A16
No load detection diagnostics	Not supported
Output short circuit/overload/ overtemp detection	Not supported
Output short circuit/overload protection	Not supported
Reverse polarity protection	Not supported
Overvoltage protections, max	Not supported
Scheduled outputs	Not supported
Pilot duty rating	Resistive/General Pilot Duty 0.5 A pilot duty
Output control in fault state per point	<ul style="list-style-type: none"> <li>• Hold Last State</li> <li>• On</li> <li>• Off (default)</li> </ul>
Output states in program mode per point	<ul style="list-style-type: none"> <li>• Hold Last State</li> <li>• On</li> <li>• Off (default)</li> </ul>
Output states in fault mode per point	<ul style="list-style-type: none"> <li>• Hold Last State</li> <li>• On</li> <li>• Off (default)</li> </ul>
Duration of fault mode per point	<ul style="list-style-type: none"> <li>• 1 s</li> <li>• 2 s</li> <li>• 5 s</li> <li>• 10 s</li> <li>• Forever (default)</li> </ul>

- (1) Level of Mod or SA power current that passes through the module depends on the system configuration, such as, module slot location and the other module types that are used in the system. For more information, see the controller user manuals in [Additional Resources on page 63](#).
- (2) Recommended Loading Resistor - To limit the effects of leakage current through solid-state outputs, you can connect a loading resistor in parallel with your load. For 120V AC operation, use a 15 KΩ, 2 W resistor. For 240V AC operation, use a 15 KΩ, 5 W resistor.

For **Certifications**, see [page 5](#).

For **Environmental Specifications**, see [page 6](#).

# 5069-0B8

## Digital 8-point 24V DC Output Module

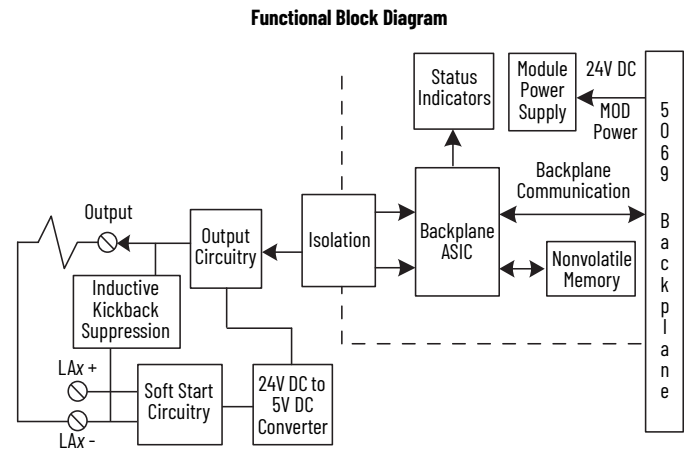
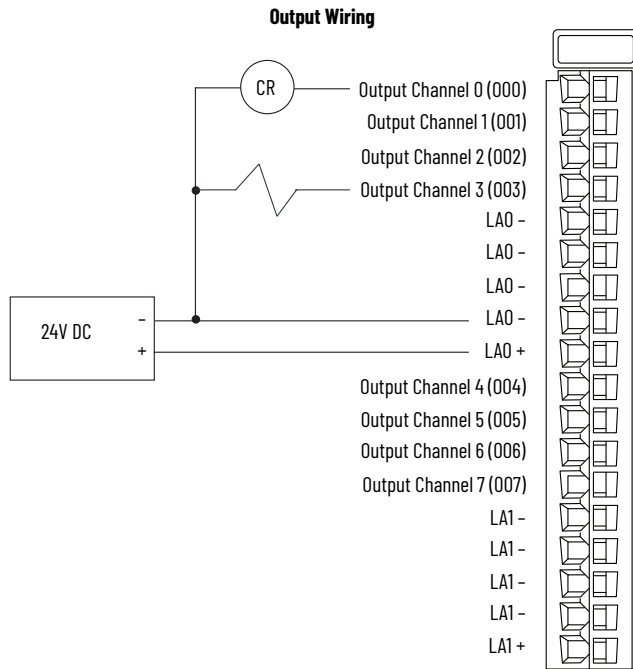

### Technical Specifications - 5069-0B8

Attribute	5069-0B8
Number of outputs	8 (two groups of 4)
Voltage category	24V DC
Voltage and current ratings	
Output voltage range	10...32V DC
MOD power	75 mA @ 18...32V DC
MOD power (passthrough) <sup>(1)</sup>	9.55 A @ 18...32V DC
LA power	2 A per channel @ 10...32V DC 8 A per group @ 10...32V DC 16 A per module @ 10...32V DC
SA power (passthrough) <sup>(1)</sup> The module does not draw SA power current.	9.95 A @ 10...32V DC
Do not exceed 10 A MOD or SA power (passthrough) current draw.	
Power dissipation, max	3.2 W
Thermal dissipation, max	10.9 BTU/hr
Isolation voltage	250V (continuous), Basic Insulation Type Type tested at 1800V AC for 60 s No isolation between LA power and output ports No isolation between individual output ports
Module keying	Electronic keying via programming software
Indicators	1 green/red module status indicator 8 yellow/red I/O status indicators
Slot width	1
Dimensions (HxWxD)	144.57 x 22 x 105.42 mm (5.69 x 0.87 x 4.15 in.)
DIN rail	Compatible zinc-plated chromate-passivated steel DIN rail. You can use the EN50022 - 35 x 7.5 mm (1.38 x 0.30 in.) DIN rail.
RTB	One of these RTB types. • 5069-RTB18-SPRING RTB • 5069-RTB18-SCREW RTB <b>IMPORTANT:</b> You must order RTBs separately. RTBs do not ship with Compact 5000 I/O modules. We recommend that you order only the RTB type that your system requires.
RTB torque (5069-RTB18-SCREW RTB only)	0.4 N·m (3.5 lb-in)
RTB keying	None

<b>Channel Connections</b>	The diagram shows devices that are connected to channels 0 and 3. You are not restricted to using only those channels. You can connect devices to any channel or combination of channels as needed.
<b>LA Power</b>	The LA+ and LA - connections are used to supply field-side power to the module. Output channels 0...3 use LA0 +/-, and output channels 4...7 use LA1 +/-.

#### IMPORTANT

Remember the following:

- The 5069-0B8 module does not draw current from the SA power bus that is internal to the system. Still, the module is a DC-type module, and you must install it on a DC SA power bus.
- If you install modules in a Compact 5000 I/O system that use AC SA power and DC SA power, you must install them on separate SA power buses.
- You use the 5069-FPD field potential distributor to establish a new SA power bus in a Compact 5000 I/O system. SA power buses are isolated from each other. To keep the modules on separate SA power buses, complete the following steps.
  - Install the modules that use one type of SA power, for example AC, to the right of the adapter or controller, that is, the first SA power bus.
  - Install the 5069-FPD field potential distributor to establish a second SA power bus.
  - Install the modules that use the other type of SA power, for example DC, on the second SA power bus.

**Technical Specifications - 5069-0B8**

Attribute	5069-0B8
Wire category	2 - output ports 2 - power ports 1 wire per terminal for each signal port
Wire size	
5069-RTB18-SPRING RTB	0.5...1.5 mm <sup>2</sup> (22...16 AWG) solid or stranded shielded copper wire rated at 105 °C (221 °F), or greater, 2.9 mm (0.11 in.) max diameter including insulation, single wire connection only.
5069-RTB18-SCREW RTB	0.5...1.5 mm <sup>2</sup> (22...16 AWG) solid or stranded shielded copper wire rated at 105 °C (221 °F), or greater, 3.5 mm (0.14 in.) max diameter including insulation, single wire connection only.
Insulation-stripping length	
5069-RTB18-SPRING RTB	10 mm (0.39 in.)
5069-RTB18-SCREW RTB	12 mm (0.47 in.)
RTB torque (5069-RTB18-SCREW RTB only)	0.4 N·m (3.5 lb-in)
Weight, approx	175 g (0.39 lb)
LA power attributes	
On-state voltage, min	10V DC
On-state voltage, nom	24V DC
On-state voltage, max	32V DC
On-state voltage drop, max	0.25V DC
Off-state voltage, max	< 10V DC
Off-state voltage, max	5V DC
On-state current per channel, min	1 mA
Off-state leakage current per point, max <sup>(2)</sup>	0.5 mA
Output current per channel, max	2 A
Output current per group, max	8 A
Output current per module, max	16 A
Surge current per point	4 A max for 10 ms per point, repeatable every 2 s
Output delay time (backplane to screw)	
Off to On	≤ 100 μs @ 25 °C (77 °F) @ 2 A
On to Off	≤ 100 μs @ 25 °C (77 °F) @ 2 A
Pulse width, min	≤ 200 μs T <sub>on</sub> min + T <sub>off</sub> min @ 2 A @ 25 °C (77 °F)
Output drift over temperature span	±100 ns/°C (55.6 n/°F) from 0...60 °C (32...140 °F) @ 2 A

**Technical Specifications - 5069-0B8**

Attribute	5069-0B8
Field power loss detection	Yes
No load detection diagnostics	Yes (per channel diagnostics)
Output short circuit/overload/overtemp detection	Yes (per channel diagnostics)
Output short circuit/overload protection	Yes
Reverse voltage protection	Yes
Overtoltage protection, max	36V (fuse protected)
Pilot duty rating	Resistive/General Pilot Duty 2 A pilot duty
Output control in fault state per point	<ul style="list-style-type: none"> <li>• Hold Last State</li> <li>• On</li> <li>• Off (default)</li> </ul>
Output states in program mode per point	<ul style="list-style-type: none"> <li>• Hold Last State</li> <li>• On</li> <li>• Off (default)</li> </ul>
Output states in fault mode per point	<ul style="list-style-type: none"> <li>• Hold Last State</li> <li>• On</li> <li>• Off (default)</li> </ul>
Duration of fault mode per point	<ul style="list-style-type: none"> <li>• 1 s</li> <li>• 2 s</li> <li>• 5 s</li> <li>• 10 s</li> <li>• Forever (default)</li> </ul>

- (1) Level of Mod or SA power current that passes through the module depends on the system configuration, such as, module slot location and the other module types that are used in the system. For more information, see the controller user manuals in [Additional Resources on page 63](#).
- (2) Recommended Loading Resistor - To limit the effects of leakage current through solid-state outputs, you can connect a loading resistor in parallel with your load. For 24V DC operation, use a 5.6 KΩ, 0.5 W resistor for transistor outputs.

For **Certifications**, see [page 5](#).  
For **Environmental Specifications**, see [page 6](#).



# 5069-OB16, 5069-OB16K, 5069-OB16F

## Digital 16-point Sourcing Output Modules

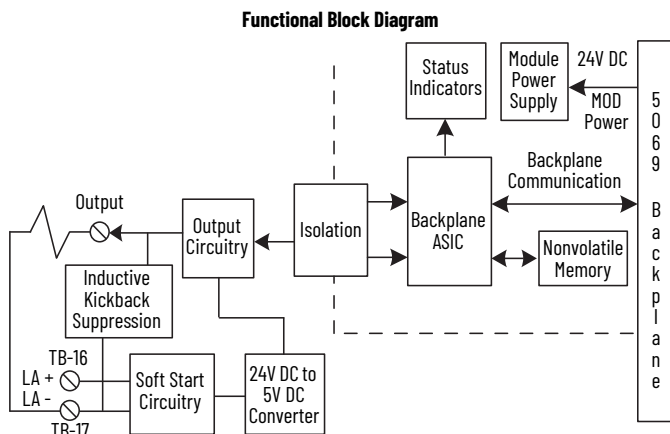
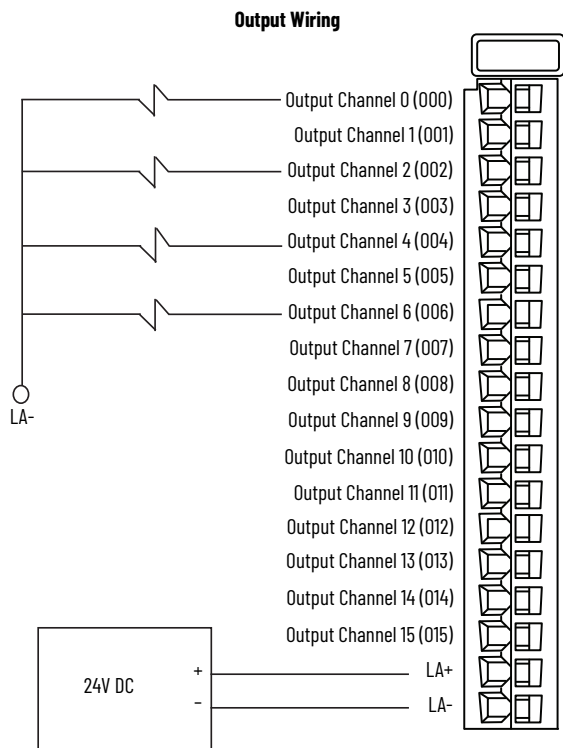

### Technical Specifications - 5069-OB16, 5069-OB16K, 5069-OB16F

Attribute	5069-OB16, 5069-OB16K	5069-OB16F
Outputs	16 Channels (1 group of 16), sourcing	
Voltage category	12/24V DC source	
Voltage and current ratings		
MOD power	75 mA @ 18...32V DC	
MOD power (passthrough) <sup>(1)</sup>	9.55 A @ 18...32V DC	
LA Power	0.5 A per channel @ 10...32V DC 8 A per module @ 10...32V DC	
SA power (passthrough) <sup>(1)</sup> The module does not draw SA power current.	9.95 A @ 10...32V DC	
Do not exceed 10 A MOD or SA power (passthrough) current draw		
Power dissipation, max	3.25 W (16 channels @ 0.5 A)	
Thermal dissipation, max	11.09 BTU/hr	
Isolation voltage	250V (continuous), Basic Insulation Type No isolation between LA power and output ports No isolation between individual output ports	
Module keying	Electronic, module keying, software configurable	
Indicators	1 green/red module status indicator 16 yellow/red I/O status indicators	
Slot width	1	
Dimensions (HxWxD), approx	144.57 x 22 x 105.42 mm (5.69 x 0.87 x 4.15 in.)	
DIN rail	Compatible zinc-plated chromate-passivated steel DIN rail. You can use the EN50022 - 35 x 7.5 mm (1.38 x 0.30 in.) DIN rail.	
RTB	One of these RTB types. • 5069-RTB18-SPRING RTB • 5069-RTB18-SCREW RTB <b>IMPORTANT:</b> You must order RTBs separately. RTBs do not ship with Compact 5000 I/O modules. We recommend that you order only the RTB type that your system requires.	
RTB torque (5069-RTB18-SCREW RTB only)	0.4 N•m (3.5 lb•in)	
RTB keying	None	

<b>Channel Connections</b>	The diagram shows devices that are connected to channels 0, 2, 4, and 6. You are not restricted to using only those channels. You can connect devices to any channel or combination of channels as needed.
<b>LA Power</b>	The LA+ and LA- connections are used to supply field-side power to the module. The module does not draw current from the SA power bus that is internal to the system.

**IMPORTANT**

- Remember the following:
- The 5069-OB16, 5069-OB16K, and 5069-OB16F modules do not draw current from the SA power bus. Still, the modules are DC type modules, and you must install them on a DC SA power bus.
  - If you install modules in a Compact 5000 I/O system that use AC SA power and DC SA power, you must install them on separate SA power buses.
  - You use the 5069-FPD field potential distributor to establish a new SA power bus in a Compact 5000 I/O system. SA power buses are isolated from each other. To keep the modules on separate SA power buses, complete the following steps.
    - Install the modules that use one type of SA power, for example AC, to the right of the adapter or controller, that is, the first SA power bus.
    - Install the 5069-FPD field potential distributor to establish a second SA power bus.
    - Install the modules that use the other type of SA power, for example DC, on the second SA power bus.

**Technical Specifications - 5069-0B16, 5069-0B16K, 5069-0B16F**

Attribute	5069-0B16, 5069-0B16K	5069-0B16F
Wire category <sup>(2)</sup>	2 - output ports 2 - power ports 1 wire per terminal for each signal port	
Wire size		
5069-RTB18-SPRING RTB	0.5...1.5 mm <sup>2</sup> (22...16 AWG) solid or stranded copper wire rated at 105 °C (221 °F), or greater, 2.9 mm (0.11 in.) max diameter including insulation	
5069-RTB18-SCREW RTB	0.5...1.5 mm <sup>2</sup> (22...16 AWG) solid or stranded copper wire rated at 105 °C (221 °F), or greater, 3.5 mm (0.14 in.) max diameter including insulation	
Insulation-stripping length		
5069-RTB18-SPRING RTB	10 mm (0.39 in.)	
5069-RTB18-SCREW RTB	12 mm (0.47 in.)	
Weight, approx	175 g (0.39 lb)	
LA power attributes		
On-state voltage, min	10V DC	
On-state voltage, nom	24V DC	
On-state voltage, max	32V DC	
On-state voltage drop, max	< 0.2V DC	
On-state current per channel, min	1 mA	
Off-state voltage, max	5V DC with 1 mA min load	
Off-state leakage current per point, max <sup>(3)</sup>	< 0.5 mA per point	
Output current rating	0.5 A resistive per channel @ 10...32V DC 8 A resistive per module @ 10...32V DC, max	
Surge current per point	1 A max for 10 ms per point, repeatable every 2 s	
Output delay time (backplane to screw)		
Off to On	≤ 100 μs, ±10 μs @ 25 °C (77 °F) @ 0.5 A	10 μs, ±1 μs @ 25 °C (77 °F) @ 0.5 A
On to Off	≤ 100 μs, ±10 μs @ 25 °C (77 °F) @ 0.5 A	10 μs, ±1 μs @ 25 °C (77 °F) @ 0.5 A
Pulse width, min	200 μs @ 0.5 A @ 25 °C (77 °F)	20 μs @ 0.5 A @ 25 °C (77 °F)
Output drift over temperature span	±100 ns/°C (55.6 ns/°F) from 0...60 °C (32...140 °F) @ 0.5 A	±10 ns/°C (5.56 ns/°F) from 0...60 °C (32...140 °F) @ 0.5 A

**Technical Specifications - 5069-0B16, 5069-0B16K, 5069-0B16F**

Attribute	5069-0B16, 5069-0B16K	5069-0B16F
Field power loss detection (Series B hardware only)	Yes	
No load detection diagnostics	Yes (per channel diagnostics)	
Output short circuit/overload/overtemp detection	Yes (per channel diagnostics)	
Output short circuit/overload protection	Yes	
Reverse voltage protection	Yes	
Overvoltage protection, max	36V (fuse protected)	
Pilot duty rating	0.5 A pilot duty rating per channel @ 10...32V DC	
Output control in fault state per point	<ul style="list-style-type: none"> <li>• Hold Last State</li> <li>• On</li> <li>• Off (default)</li> </ul>	
Output states in program mode per point	<ul style="list-style-type: none"> <li>• Hold Last State</li> <li>• On</li> <li>• Off (default)</li> </ul>	
Output states in fault mode per point	<ul style="list-style-type: none"> <li>• Hold Last State</li> <li>• On</li> <li>• Off (default)</li> </ul>	
Duration of fault mode per point	<ul style="list-style-type: none"> <li>• 1 s</li> <li>• 2 s</li> <li>• 5 s</li> <li>• 10 s</li> <li>• Forever (default)</li> </ul>	
Scheduled outputs	Not supported	±10 μs accuracy 1 ns resolution

- (1) Level of Mod or SA power current that passes through the module depends on the system configuration, such as, module slot location and the other module types that are used in the system. For more information, see the controller user manuals in [Additional Resources on page 63](#).
- (2) Use this Conductor Category information to plan conductor routes. See the Industrial Automation Wiring and Grounding Guidelines, publication [1770-4.1](#).
- (3) Recommended Loading Resistor - To limit the effects of leakage current through solid-state outputs, connect a loading resistor in parallel with your load. For 24V DC operation, use a 5.6 KΩ, 0.5 W resistor for transistor operation.

For **Certifications**, see [page 5](#).  
For **Environmental Specifications**, see [page 6](#).

# 5069-0W4I

## Digital 4-point Isolated Relay Output Module

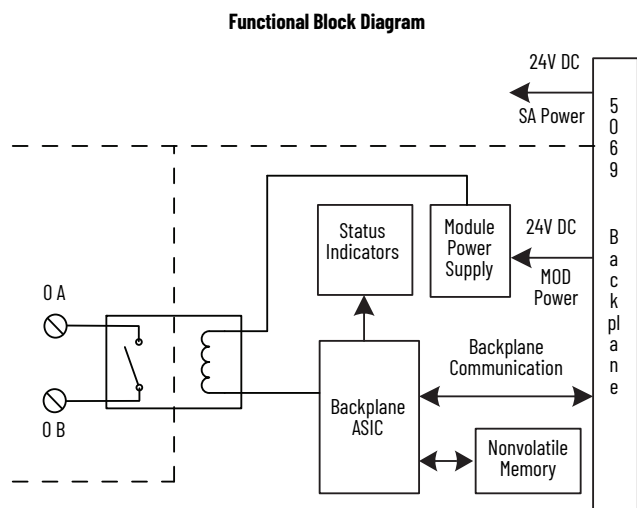
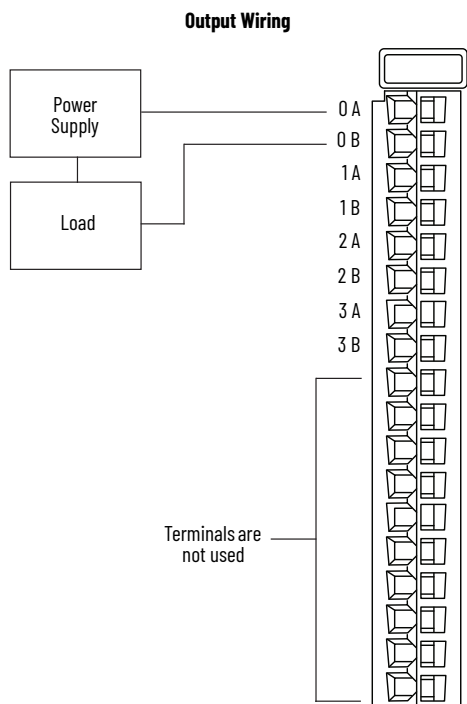

**Channel Connections** The diagram shows a device that is connected to channel 0. You are not restricted to using only this channel. You can connect devices to any channel or combination of channels as needed.

- IMPORTANT**  
Remember the following:
- The 5069-0W4I module does not draw current from the SA power bus. Still, the module is a DC-type module, and you must install it on a DC SA power bus.
  - If you install modules in a Compact 5000 I/O system that use AC SA power and DC SA power, you must install them on separate SA power buses.
  - You use the 5069-FPD field potential distributor to establish a new SA power bus in a Compact 5000 I/O system. SA power buses are isolated from each other. To keep the modules on separate SA power buses, complete the following steps.
    - Install the modules that use one type of SA power, for example AC, to the right of the adapter or controller, that is, the first SA power bus.
    - Install the 5069-FPD field potential distributor to establish a second SA power bus.
    - Install the modules that use the other type of SA power, for example DC, on the second SA power bus.

### Technical Specifications - 5069-0W4I

Attribute	5069-0W4I
Outputs	4 - Form A (normally open)
Voltage and current ratings	
Output voltage range	5...125V DC 5...264V AC
MOD power	75 mA @ 18...32V DC
MOD power (passthrough) <sup>(1)</sup>	9.55 A @ 18...32V DC
SA power (passthrough) <sup>(1)</sup> The module does not draw SA power current.	9.95 A @ 0...32V DC
Do not exceed 10 A MOD or SA power (passthrough) current draw	
Power dissipation, max	2.3 W
Thermal dissipation, max	7.85 BTU/hr
Isolation voltage	250V (continuous), Basic Insulation Type
Module keying	Electronic keying via programming software
Slot width	1
Dimensions (HxWxD), approx	144.57 x 22 x 105.42 mm (5.69 x 0.87 x 4.15 in.)
DIN rail	Compatible zinc-plated chromate-passivated steel DIN rail. You can use the EN50022 - 35 x 7.5 mm (1.38 x 0.30 in.) DIN rail.
RTB	One of these RTB types. <ul style="list-style-type: none"> <li>5069-RTB18-SPRING RTB</li> <li>5069-RTB18-SCREW RTB</li> </ul> <b>IMPORTANT:</b> You must order RTBs separately. RTBs do not ship with Compact 5000 I/O modules. We recommend that you order only the RTB type that your system requires.
RTB torque (5069-RTB18-SCREW RTB only)	0.4 N•m (3.5 lb•in)
RTB keying	None
Indicators	1 green/red module status indicator 4 yellow/red I/O status indicators

### Technical Specifications - 5069-0W4I

Attribute	5069-0W4I
Wire category <sup>(2)</sup>	1 - relay ports 2 - power ports 1 wire per terminal for each signal port
Wire size	
5069-RTB18-SPRING RTB	0.5...1.5 mm <sup>2</sup> (22...16 AWG) solid or stranded copper wire rated at 105 °C (221 °F), or greater, 2.9 mm (0.11 in.) max diameter including insulation Use minimum 18 AWG, 105 °C (221 °F) rated wire for load connections to relay output modules.
5069-RTB18-SCREW RTB	0.5...1.5 mm <sup>2</sup> (22...16 AWG) solid or stranded copper wire rated at 105 °C (221 °F), or greater, 3.5 mm (0.14 in.) max diameter including insulation Use minimum 18 AWG, 105 °C (221 °F) rated wire for load connections to relay output modules.
Insulation-stripping length	
5069-RTB18-SPRING RTB	10 mm (0.39 in.)
5069-RTB18-SCREW RTB	12 mm (0.47 in.)
Weight, approx	175 g (0.39 lb)
Relay rating <sup>(3)</sup>	2 A resistive per channel @ 5...30V DC 2 A resistive per channel @ 5...264V AC, 50/60 Hz 2 A general use per channel @ 5...250V AC, 50/60 Hz 2 A @ 5...125V AC, UKEX/ATEX/IECEX 8 A per module, max
Off-state leakage	0 mA (dry contact, no onboard snubbers)
Output current rating, max	2 A per channel 8 A per module
Output delay time, max	
Off to On	10 ms
On to Off	10 ms
Switching frequency	1 operation every 3 seconds (0.3 Hz at rated load)
Initial contact resistance, max	30 mΩ
Bounce time, mean	500 μs

### Technical Specifications - 5069-0W4I

Attribute	5069-0W4I
Output control in fault state per point	<ul style="list-style-type: none"> <li>Hold last state</li> <li>On</li> <li>Off (default)</li> </ul>
Output states in program mode per point	<ul style="list-style-type: none"> <li>Hold last state</li> <li>On</li> <li>Off (default)</li> </ul>
Output states in fault mode per point	<ul style="list-style-type: none"> <li>Hold Last State</li> <li>On</li> <li>Off (default)</li> </ul>
Duration of fault mode per point	<ul style="list-style-type: none"> <li>1 s</li> <li>2 s</li> <li>5 s</li> <li>10 s</li> <li>Forever (default)</li> </ul>
Delay to fault	Supported
Fusing	Outputs aren't fused.
Minimum load current	1 mA
Expected contact life	300K cycles resistive, 100K cycles inductive
Pilot duty rating	5...240V AC, 50/60 Hz, C300 pilot duty per channel 5...125V DC, R150 pilot duty per channel

- (1) Level of Mod or SA power current that passes through the module depends on the system configuration, such as, module slot location and the other module types that are used in the system. For more information, see the controller user manuals in [Additional Resources on page 63](#).
- (2) Use this Conductor Category information to plan conductor routes. See the Industrial Automation Wiring and Grounding Guidelines, publication [1770-4.1](#).
- (3) **Surge Suppression** - To extend the life of the module, connect surge suppressors across your external inductive load. For additional details, see the Industrial Automation Wiring and Grounding Guidelines, Allen-Bradley® publication [1770-4.1](#).

### Relay Contact Ratings - 5069-0W4I

Volts, Max	Continuous Amps per Point, Max	Amperes		Voltamperes		NEMA ICS 2-125
		Make	Break	Make	Break	
240V AC	2 A	7.5 A	0.75 A	1800VA	180VA	C300
125V DC	0.27 A <sup>(1)</sup>	0.22 A <sup>(2)</sup>		28VA		R150
24V DC	2.0 A	1.16 A <sup>(2)</sup>		28VA		-

- (1) Calculated based on the Rockwell Automation® component derating guideline: 90% of rated contact current, that is, 0.3 A at 125V DC.
- (2) For DC voltage applications, to determine the make/break ampere rating for relay contacts, divide 28VA by the applied DC voltage. For example, 28VA/48V DC = 0.58 A.

For **Certifications**, see [page 5](#).

For **Environmental Specifications**, see [page 6](#).

# 5069-0W16

## Digital 16-point Relay Output Module

You can connect AC-type devices, DC-type devices, or a combination of the two types to the module, as shown in the following diagram. Because the module has two commons, each shared across a set of eight output channels, make sure that you do not connect devices of different power types to the same set of commons. For example, you cannot connect a device that uses AC-type power to output channel 0 and a device that uses DC-type power to output channel 1.

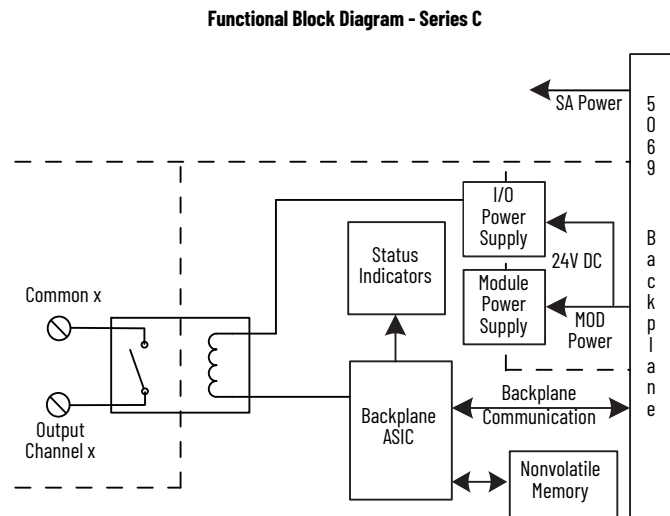
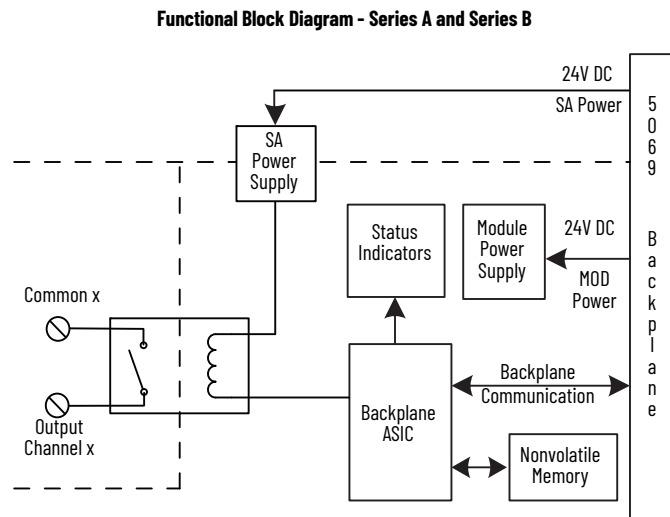
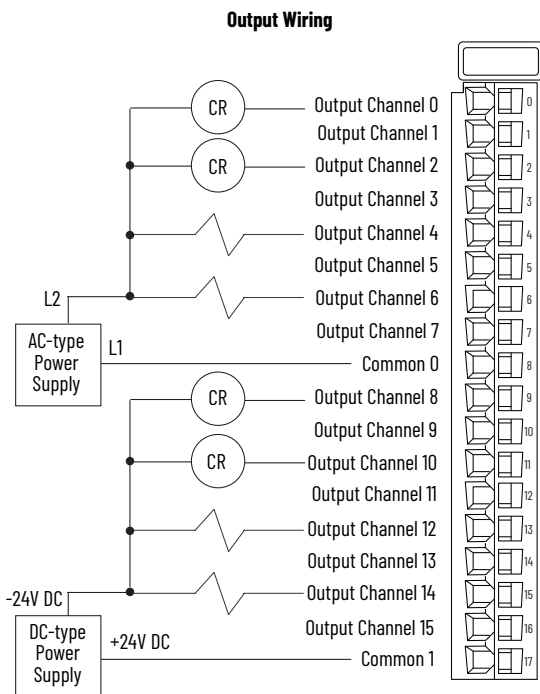

<b>Channel Connections</b>	The example shows devices that are connected to channels 0, 2, 4, 6, 8, 10, 12, and 14. You are not restricted to using only those channels. You can connect devices to any channel or combination of channels as needed.
<b>SA Power</b>	For <b>Series A</b> and <b>Series B</b> modules, connections to an external power supply that provides SA power are made via the SA power RTB on one of the following: <ul style="list-style-type: none"> <li>• CompactLogix 5380 controller</li> <li>• Compact GuardLogix 5380 controller</li> <li>• CompactLogix 5480 controller</li> <li>• 5069-AENTR or 5069-AEN2TR EtherNet/IP Adapter</li> <li>• 5069-FPD field potential distributor</li> </ul>

**IMPORTANT**

- For **Series A** and **Series B** modules, remember the following:
- The 5069-0W16 Series A and Series B modules require DC SA power. You must connect DC power to the component, that is, the controller, adapter, or field potential distributor, that provides SA power to the module.
  - If you install modules in a system that uses AC SA power and DC SA power, you must install them on separate SA power buses.
  - You use a 5069-FPD field potential distributor to establish a new SA power bus in a system. SA power buses are isolated from each other. To keep the modules on separate SA power buses, complete these steps.
    1. Install the modules that use one type of SA power, for example DC, to the right of the adapter or controller, that is, the first SA power bus.
    2. Install the 5069-FPD field potential distributor to establish a second SA power bus.
    3. Install the modules that use the other type of SA power, for example AC, on the second SA power bus.

**IMPORTANT**

For **Series C** modules, remember the following:  
 The 5069-0W16 Series C module does not use SA power. That is, it does not draw current from the SA power bus. The module passes it through to the next Compact 5000 I/O module in the system.

### Technical Specifications - 5069-0W16

Attribute	5069-0W16
Outputs	16 (Two groups of 8) - Form A (normally open)
Voltage and current ratings	
Output voltage range	5...125V DC, 5...264V AC
MOD power	Series A and B: 75 mA @ 18...32V DC Series C: 225 mA @ 18...32V DC
MOD power (passthrough) <sup>(1)</sup>	9.55 A @ 18...32V DC
SA power	Series A and B: 150 mA @ 18...32V DC Series C: -
SA power (passthrough) <sup>(1)</sup>	9.95 A @ 18...32V DC
Do not exceed 10 A MOD or SA power (passthrough) current draw. The 5069-0W16 module complies with UKEX/ATEX/IECEx when used at or below 125V AC or 30V DC.	
Power dissipation, max	3.0 W
Thermal dissipation, max	10.2 BTU/hr
Isolation voltage	250V (continuous), Basic Insulation Type Type tested at 1800V AC for 60 s No isolation between individual channels
Module keying	Electronic keying via programming software
Indicators	1 green/red module status indicator 16 yellow/red I/O status indicators
Slot width	1.5
Dimensions (HxWxD), approx	144.57 x 36 x 105.42 mm (5.69 x 1.42 x 4.15 in.)
DIN rail	Compatible zinc-plated chromate-passivated steel DIN rail. Use the EN50022 - 35 x 7.5 mm (1.38 x 0.30 in.) DIN rail.
RTB	One of these RTB types. • 5069-RTB18-SPRING RTB • 5069-RTB18-SCREW RTB <b>IMPORTANT:</b> You must order RTBs separately. RTBs do not ship with Compact 5000 I/O modules. We recommend that you order only the RTB type that your system requires.
RTB torque (5069-RTB18-SCREW RTB only)	0.4 N-m (3.5 lb-in)
RTB keying	None
Wire category <sup>(2)</sup>	1 - relay ports 2 - power ports 1 wire per terminal for each signal port
Wire size	
5069-RTB18-SPRING RTB	0.5...1.5 mm <sup>2</sup> (22...16 AWG) solid or stranded shielded copper wire rated at 105 °C (221 °F), or greater, 2.9 mm (0.11 in.) max diameter including insulation, single wire connection only. Use minimum 18 AWG, 105 °C (221 °F) rated wire for load connections to relay output modules.
5069-RTB18-SCREW RTB	0.5...1.5 mm <sup>2</sup> (22...16 AWG) solid or stranded shielded copper wire rated at 105 °C (221 °F), or greater, 3.5 mm (0.14 in.) max diameter including insulation, single wire connection only. Use minimum 18 AWG, 105 °C (221 °F) rated wire for load connections to relay output modules.
Insulation-stripping length	
5069-RTB18-SPRING RTB	10 mm (0.39 in.)
5069-RTB18-SCREW RTB	12 mm (0.47 in.)
Weight, approx	240 g (0.53 lb.)
Relay ratings <sup>(3)</sup>	2 A resistive per channel @ 5...30V DC 2 A resistive per channel @ 5...264V AC, 50/60 Hz 2 A general use per channel @ 5...250V AC, 50/60 Hz 2 A @ 5...125V AC, UKEX/ATEX/IECEx
Off-state leakage current per point, max	0 mA (dry contact, no onboard snubbers)
Output current per group, max	8 A
Output current per module, max	16 A

### Technical Specifications - 5069-0W16

Attribute	5069-0W16
Output delay time, max	
Off to On	10 ms
On to Off	10 ms
Switching frequency	1 operation every 3 seconds (0.3 Hz at rated load)
Initial contact resistance, max	30 mΩ
Bounce time, mean	500 μs
Delay to fault	Supported
Fusing	Outputs are not fused
Minimum load current	1 mA
Expected contact life	300K cycles resistive, 100K cycles inductive
Pilot duty rating	5...240V AC, 50/60 Hz, C300 pilot duty per channel 5...125V DC, R150 pilot duty per channel
Output control in fault state per point	<ul style="list-style-type: none"> <li>Hold Last State</li> <li>On</li> <li>Off (default)</li> </ul>
Output states in program mode per point	<ul style="list-style-type: none"> <li>Hold Last State</li> <li>On</li> <li>Off (default)</li> </ul>
Output states in fault mode per point	<ul style="list-style-type: none"> <li>Hold Last State</li> <li>On</li> <li>Off (default)</li> </ul>
Duration of fault mode per point	<ul style="list-style-type: none"> <li>1</li> <li>2</li> <li>5</li> <li>10 s</li> <li>Forever (default)</li> </ul>

- (1) Level of Mod or SA power current that passes through the module depends on the system configuration, such as, module slot location and the other module types that are used in the system. For more information, see the controller user manuals in [Additional Resources on page 63](#).
- (2) Use this Conductor Category information to plan conductor routes. See the Industrial Automation Wiring and Grounding Guidelines, publication [1770-4.1](#).
- (3) **Surge Suppression** - To extend the life of the module, connect surge suppressors across your external inductive load. For additional details, see the Industrial Automation Wiring and Grounding Guidelines, Allen-Bradley publication [1770-4.1](#).

### Relay Contact Ratings - 5069-0W16

Volts, Max	Continuous Amps per Point, Max	Amperes		Voltamperes		NEMA ICS 2-125
		Make	Break	Make	Break	
240V AC	2 A	7.5 A	0.75 A	1800VA	180VA	C300
125V DC	0.27 A <sup>(1)</sup>	0.22 A <sup>(2)</sup>		28VA		R150
24V DC	2.0 A	1.16 A <sup>(2)</sup>		28VA		-

- (1) Calculated based on the Rockwell Automation component derating guideline: 90% of rated contact current, that is, 0.3 A at 125V DC.
- (2) For DC voltage applications, to determine the make/break ampere rating for relay contacts, divide 28VA by the applied DC voltage. For example, 28VA/48V DC = 0.58 A.

For **Certifications**, see [page 5](#).

For **Environmental Specifications**, see [page 6](#).

# 5069-0X4I

## Digital 4-point Isolated Normally-open/Normally-closed Output Module

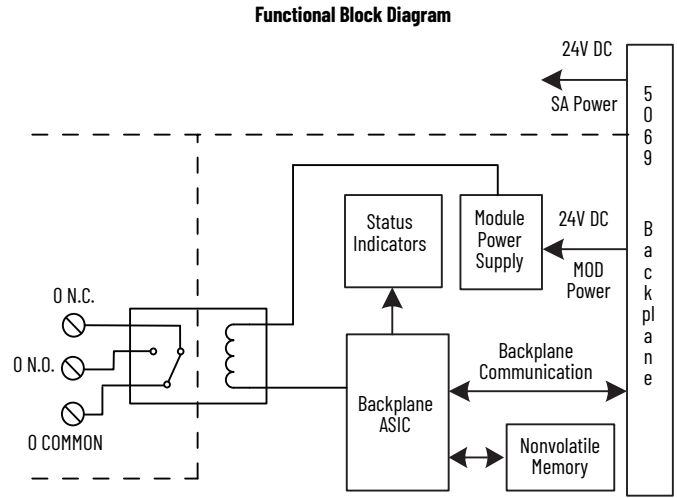
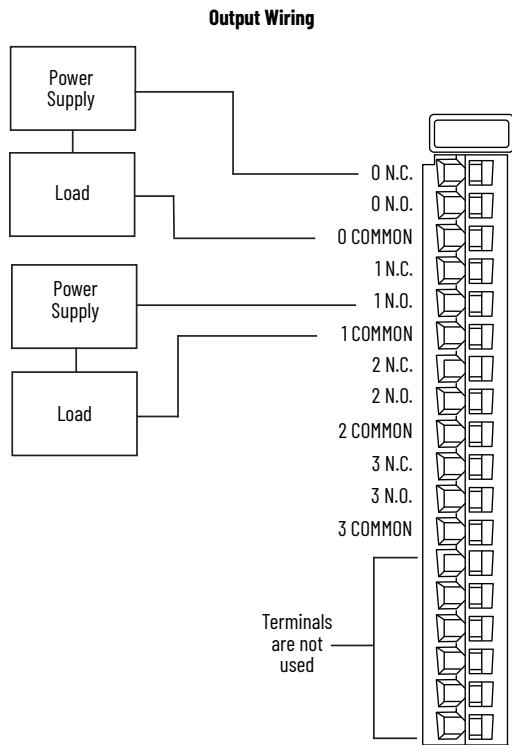

### Technical Specifications - 5069-0X4I

Attribute	5069-0X4I
Outputs	4 - Form C (SPDT)
Voltage and current ratings	
Output voltage range	5...125V DC 5...264V AC
MOD power	75 mA @ 18...32V DC
MOD power (passthrough) <sup>(1)</sup>	9.55 A @ 18...32V DC
SA power (passthrough) <sup>(1)</sup> The module does not draw SA power current.	9.95 A @ 0...32V DC
Do not exceed 10 A MOD or SA power (passthrough) current draw	
Power dissipation, max	2.6 W
Thermal dissipation, max	8.88 BTU/hr
Isolation voltage	250V (continuous), Basic Insulation Type
Module keying	Electronic keying via programming software
Slot width	1
Dimensions (HxWxD), approx	144.57 x 22 x 105.42 mm (5.69 x 0.87 x 4.15 in.)
DIN rail	Compatible zinc-plated chromate-passivated steel DIN rail. You can use the EN50022 - 35 x 7.5 mm (1.38 x 0.30 in.) DIN rail.
RTB	One of these RTB types. <ul style="list-style-type: none"> <li>• 5069-RTB18-SPRING RTB</li> <li>• 5069-RTB18-SCREW RTB</li> </ul> <b>IMPORTANT:</b> You must order RTBs separately. RTBs do not ship with Compact 5000 I/O modules. We recommend that you order only the RTB type that your system requires.
RTB torque (5069-RTB18-SCREW RTB only)	0.4 N•m (3.5 lb•in)
RTB keying	None

**Channel Connections** The diagram shows devices that are connected to channels 0 and 1. You are not restricted to using only those channels. You can connect devices to any channel or combination of channels as needed.

- IMPORTANT**  
Remember the following:
- The 5069-0X4I module does not draw current from the SA power bus. Still, the module is a DC-type module, and you must install it on a DC SA power bus.
  - If you install modules in a system that uses AC SA power and DC SA power, you must install them on separate SA power buses.
  - You use a 5069-FPD field potential distributor to establish a new SA power bus in a system. SA power buses are isolated from each other. To keep the modules on separate SA power buses, complete these steps.
    1. Install the modules that use one type of SA power, for example DC, to the right of the adapter or controller, that is, the first SA power bus.
    2. Install the 5069-FPD field potential distributor to establish a second SA power bus.
    3. Install the modules that use the other type of SA power, for example AC, on the second SA power bus.

### Technical Specifications - 5069-0X4I

Attribute	5069-0X4I
Indicators	1 green/red module status indicator 4 yellow/red I/O status indicators
Wire category <sup>(2)</sup>	1 - relay ports 2 - power ports 1 wire per terminal for each signal port
Wire size	
5069-RTB18-SPRING RTB	0.5...1.5 mm <sup>2</sup> (22...16 AWG) solid or stranded copper wire rated at 105 °C (221 °F), or greater, 2.9 mm (0.11 in.) max diameter including insulation Use minimum 18 AWG, 105 °C (221 °F) rated wire for load connections to relay output modules.
5069-RTB18-SCREW RTB	0.5...1.5 mm <sup>2</sup> (22...16 AWG) solid or stranded copper wire rated at 105 °C (221 °F), or greater, 3.5 mm (0.14 in.) max diameter including insulation Use minimum 18 AWG, 105 °C (221 °F) rated wire for load connections to relay output modules.
Insulation-stripping length	
5069-RTB18-SPRING RTB	10 mm (0.39 in.)
5069-RTB18-SCREW RTB	12 mm (0.47 in.)
Weight, approx	175 g (0.39 lb)
Contact current rating <sup>(3)</sup>	2 A resistive per channel @ 5...30V DC 2 A resistive per channel @ 5...264V AC, 50/60 Hz 2 A general use per channel @ 5...250V AC, 50/60 Hz 2 A @ 5...125V AC, UKEX/ATEX/IECEx 8 A per module, max
Off-state leakage	0 mA (dry contact, no onboard snubbers)
Output current rating	2 A per channel 8 A per module, max
Output delay time, max	
Off to On	15 ms
On to Off	15 ms
Switching frequency	1 operation every 3 seconds (.3 Hz at rated load)
Initial contact resistance, max	30 mΩ
Bounce time, mean	500 μs
Output control in fault state per point	<ul style="list-style-type: none"> <li>Hold last state</li> <li>On</li> <li>Off (default)</li> </ul>
Output states in program mode per point	<ul style="list-style-type: none"> <li>Hold last state</li> <li>On</li> <li>Off (default)</li> </ul>
Output states in fault mode per point	<ul style="list-style-type: none"> <li>Hold Last State</li> <li>On</li> <li>Off (default)</li> </ul>

### Technical Specifications - 5069-0X4I

Attribute	5069-0X4I
Duration of fault mode per point	<ul style="list-style-type: none"> <li>1 s</li> <li>2 s</li> <li>5 s</li> <li>10 s</li> <li>Forever (default)</li> </ul>
Delay to fault	Supported
Fusing	Outputs aren't fused.
Minimum load current	10 mA
Expected contact life	300K cycles resistive, 100K cycles inductive
Pilot duty rating	5...240V AC, 50/60 Hz, C300 pilot duty per channel 5...125V DC, R150 pilot duty per channel

- (1) Level of Mod or SA power current that passes through the module depends on the system configuration, such as, module slot location and the other module types that are used in the system. For more information, see the controller user manuals in [Additional Resources on page 63](#).
- (2) Use this Conductor Category information to plan conductor routes. See the Industrial Automation Wiring and Grounding Guidelines, publication [1770-4.1](#).
- (3) **Surge Suppression** - To extend the life of the module, connect surge suppressors across your external inductive load. For additional details, see the Industrial Automation Wiring and Grounding Guidelines, Allen-Bradley publication [1770-4.1](#).

### Relay Contact Ratings - 5069-0X4I

Volts, Max	Continuous Amps per Point, Max	Amperes		Voltamperes		NEMA ICS 2-125
		Make	Break	Make	Break	
240V AC	2 A	7.5 A	0.75 A	1800VA	180VA	C300
125V DC	0.225 A <sup>(1)</sup>	0.22 A <sup>(2)</sup>		28VA		R150
24V DC	2.0 A	1.16 A <sup>(2)</sup>		28VA		-

- (1) Calculated based on the Rockwell Automation component derating guideline: 90% of rated contact current, that is, 0.25 A at 125V DC.
- (2) For DC voltage applications, to determine the make/break ampere rating for relay contacts, divide 28VA by the applied DC voltage. For example, 28VA/48V DC = 0.58 A.

For **Certifications**, see [page 5](#).

For **Environmental Specifications**, see [page 6](#).



## Analog I/O Modules

The following analog I/O modules are available.

I/O Type	Cat. No.	Description	Page
Analog input	5069-IF8	8-channel current/voltage input module	27
	5069-IY4	4-channel current/voltage/RTD/Thermocouple input module	30
	5069-IY4K	4-channel conformal coated current/voltage/RTD/Thermocouple input module	
Analog output	5069-OF4	4-channel current/voltage output module	36
	5069-OF4K	4-channel conformal coated current/voltage output module	
	5069-OF8	8-channel current/voltage output module	

### Certifications - Analog I/O Modules

Certification <sup>(1)</sup>	5069-IF8, 5069-IY4, 5069-IY4K, 5069-OF4, 5069-OF4K, 5069-OF8
c-UL-us	UL Listed Industrial Control Equipment, certified for US and Canada. See UL File E65584. UL Listed for Class I, Division 2 Group A,B,C,D Hazardous Locations, certified for U.S. and Canada. See UL File E194810.
UKCA and CE	UK Statutory Instrument 2016 No. 1091 and European Union 2014/30/EU EMC Directive, compliant with: EN 61326-1; Meas./Control/Lab., Industrial Requirements EN 61000-6-2; Industrial Immunity EN 61000-6-4; Industrial Emissions EN 61131-2; Programmable Controllers (Clause 8, Zone A & B)  UK Statutory Instrument 2016 No. 1101 and European Union 2014/35/EU LVD, compliant with: EN 61010-2-201; Control Equipment Safety Requirements  UK Statutory Instrument 2012 No. 3032 and European Union 2011/65/EU RoHS, compliant with: EN IEC 63000; Technical documentation
RCM	Australian Radiocommunications Act, compliant with: EN 61000-6-4; Industrial Emissions
Ex	UK Statutory Instrument 2016 No. 1107 and European Union 2014/34/EU ATEX Directive, compliant with: EN IEC 60079-0; General Requirements EN IEC 60079-7; Explosive Atmospheres, Protection "e" II 3 G Ex ec IIC T4 Gc DEMKO 15 ATEX 1484X and UL22UKEX2379X
IECEX	IECEX System, compliant with: IEC 60079-0; General Requirements IEC 60079-7; Explosive Atmospheres, Protection "e" II 3 G Ex ec IIC T4 Gc IECEX UL 15.0055X
KC	Korean Registration of Broadcasting and Communications Equipment, compliant with: Article 58-2 of Radio Waves Act, Clause 3
Morocco	Arrêté ministériel n° 6404-15 du 1 er muharram 1437 Arrêté ministériel n° 6404-15 du 29 ramadan 1436
CCC	CNCA-C23-01:2019强制性产品认证实施规则 防爆电气 CNCA-C23-01:2019 CCC Implementation Rule Explosion-Proof Electrical Products CCC: 2020312309000308

(1) See the Product Certification link at [rok.auto/certifications](http://rok.auto/certifications) for Declarations of Conformity, Certificates, and other certification details.

Environmental Specifications - Analog I/O Modules

Attribute	5069-IF8, 5069-IY4, 5069-IY4K, 5069-OF4, 5069-OF4K, 5069-OF8
Temperature, operating IEC 60068-2-1 (Test Ad, Operating Cold) IEC 60068-2-2 (Test Bd, Operating Dry Heat) IEC 60068-2-14 (Test Nb, Operating Thermal Shock)	0...60 °C (32...140 °F)
Temperature, surrounding air, max	60 °C (140 °F)
Temperature, nonoperating IEC 60068-2-1 (Test Ab, Unpackaged Nonoperating Cold) IEC 60068-2-2 (Test Bb, Unpackaged Nonoperating Dry Heat) IEC 60068-2-14 (Test Na, Unpackaged Nonoperating Thermal Shock)	-40...+85 °C (-40...+185 °F)
Relative humidity IEC 60068-2-30 (Test Db, Unpackaged Damp Heat)	5...95% noncondensing
Vibration IEC 60068-2-6 (Test Fc, Operating)	5 g @ 10...500 Hz
Shock, operating IEC 60068-2-27 (Test Ea, Unpackaged Shock)	30 g
Shock, nonoperating IEC 60068-2-27 (Test Ea, Unpackaged Shock)	50 g
Emissions	IEC 61000-6-4
ESD immunity IEC 61000-4-2	6 kV contact discharges 8 kV air discharges
Radiated RF immunity IEC 61000-4-3	10V/m with 1 kHz sine wave 80% AM from 80...6000 MHz
EFT/B immunity IEC 61000-4-4	±4 kV @ 5 kHz on power ports ±3 kV @ 5 kHz on input ports
Surge transient immunity IEC 61000-4-5	±1 kV line-line (DM) and ±2 kV line-earth (CM) on power ports ±2 kV line-earth (CM) on shielded input ports
Voltage variation IEC 61000-4-29	10 ms interruption on MOD power port
North American temp code	T4
UKEX/ATEX temp code	T4
IECEX temp code	T4
Enclosure type	None (open-style)

# 5069-IF8

## Analog 8-channel Current/Voltage Input Module

The following table lists the supported devices.

Supported Devices	Modes <sup>(1)</sup>
2-wire analog device	Current
3-wire analog device	Voltage
4-wire analog device <sup>(2)</sup>	Combination of current and voltage

- (1) Make sure that the channel configuration in your Logix Designer application project matches the input device type that is connected to the channel. On the Module Properties dialog box, choose the input type in the Channels category. For example, if a current input device is connected to channel 0 on the module, the module configuration for channel 0 must be Input Type = Current.
- (2) The 4-wire devices are 2-wire current and voltage devices with 2-wire sensor power connections.

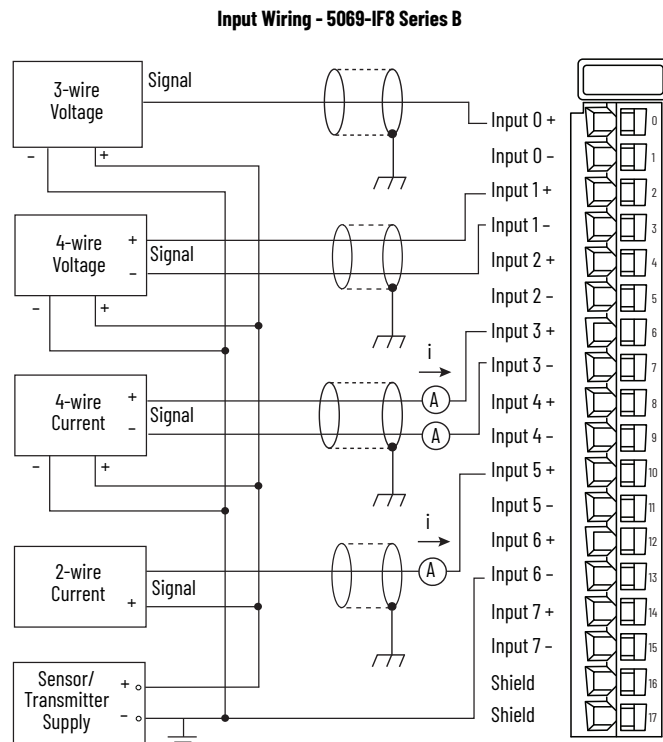

Terminal inputs 0-...7- are internally connected.

### Input Wiring - 5069-IF8 Series A

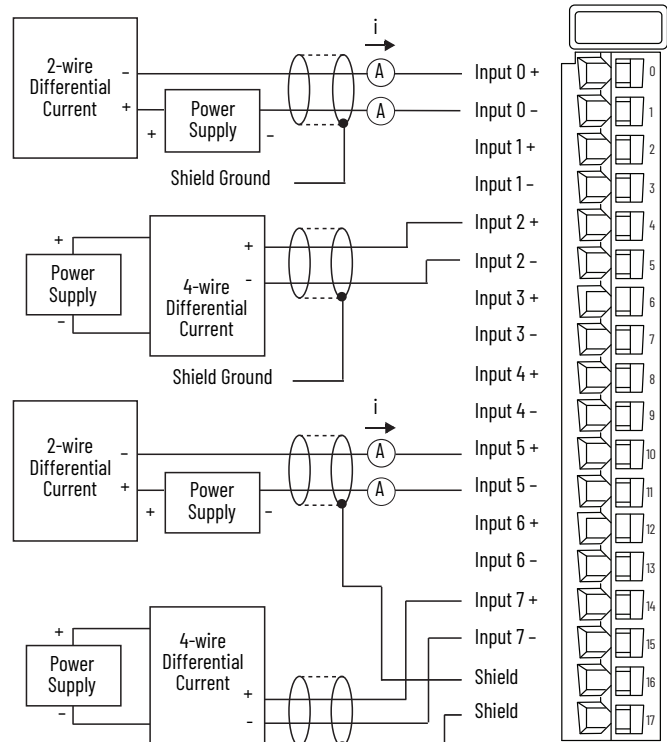

#### Channel Connections

The wiring diagrams show devices that are connected to specific channels. You are not restricted to using only these channels. You can connect devices to any channel or combination of channels as needed.

#### IMPORTANT

Remember the following:

- Place additional loop devices, for example, strip chart recorders, at either **A** location in the current loop.
- Use separate external power supplies to provide SA power to the system and to power external devices that are connected to the module.
- This module has only two shield terminals. Compact 5000 I/O module RTBs only support one wire per terminal.
- If you connect more than two devices to the module, you can ground two devices at the shield terminals.

You must ground the remaining devices somewhere else, such as, to the DIN rail via a terminal strip. In this case, use the same power supply to power the additional devices. If separate power supplies are used to power the additional devices, ground the power supplies at the same ground location.

#### SA Power

Connections to an external power supply that provides SA power are made via the SA power RTB on one of the following:

- CompactLogix 5380 controller
- Compact GuardLogix 5380 controller
- CompactLogix 5480 controller
- 5069-AENTR or 5069-AEN2TR EtherNet/IP Adapter
- 5069-FPD field potential distributor

#### IMPORTANT

Remember the following:

- The 5069-IF8 module uses DC SA power. You must connect DC power to the component, that is, the controller, adapter, or field potential distributor that provides SA power to the modules.
- If you install modules in a system that use AC SA power and DC SA power, you must install them on separate SA power buses.
- Use a 5069-FPD field potential distributor to establish a new SA power bus in a system. SA power buses are isolated from each other. To keep the modules on separate SA power buses, complete these steps.
  1. Install the modules that use one type of SA power, for example DC, to the right of the adapter or controller, that is, the first SA power bus.
  2. Install the 5069-FPD field potential distributor to establish a second SA power bus.
  3. Install the modules that use the other type of SA power, for example AC, on the second SA power bus.

**Functional Block Diagram -  
5069-IF8 Series B**

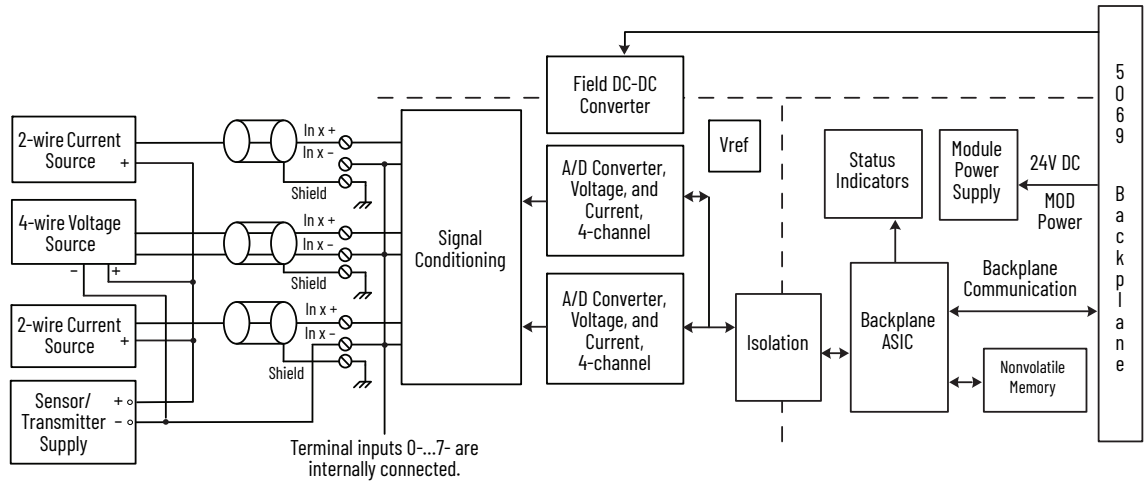

**Functional Block Diagram -  
5069-IF8 Series A**

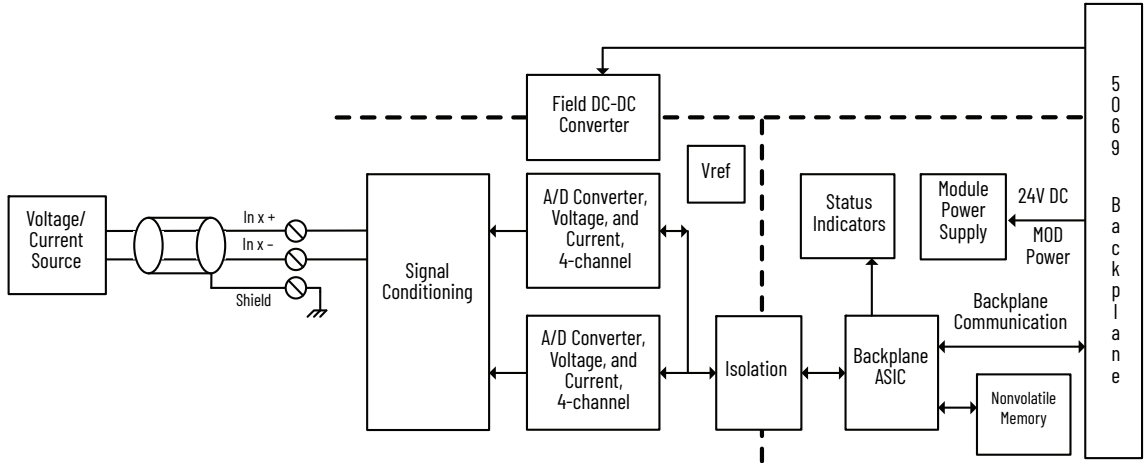

## Technical Specifications - 5069-IF8

Attribute	5069-IF8
Voltage and current ratings	
MOD power	75 mA @ 18...32V DC
MOD power (passthrough) <sup>(1)</sup>	9.55 A @ 18...32V DC
SA power	100 mA @ 18...32V DC
SA power (passthrough) <sup>(1)</sup>	9.95 A @ 18...32V DC
Do not exceed 10 A MOD or SA power (passthrough) current draw.	
Power dissipation, max	Voltage mode: 2.1 W Current mode: 2.4 W
Thermal dissipation, max	Voltage mode: 7.2 BTU/hr Current mode: 8.2 BTU/hr
Isolation voltage	250V (continuous), Basic Insulation Type 50V Functional Isolation between SA power and input ports No isolation between individual Input ports
Calibration methods	Factory calibrated User-performed (optional)
Module keying	Electronic keying via programming software
Indicators	1 green/red module status indicator 8 yellow/red I/O status indicator
Slot width	1
Common mode noise rejection ratio	130 dB @ 50/60 Hz
Normal mode noise rejection ratio	65 dB @ 50/60 Hz, notch filter dependent
Dimensions (HxWxD), approx	144.57 x 22 x 105.42 mm (5.69 x 0.87 x 4.15 in.)
DIN rail	Compatible zinc-plated chromate-passivated steel DIN rail. You can use the EN50022 - 35 x 7.5 mm (1.38 x 0.30 in.) DIN rail.
RTB	One of these RTB types. • 5069-RTB18-SPRING RTB • 5069-RTB18-SCREW RTB <b>IMPORTANT:</b> You must order RTBs separately. RTBs do not ship with Compact 5000 I/O modules. We recommend that you order only the RTB type that your system requires.
RTB torque (5069-RTB18-SCREW RTB only)	0.4 N•m (3.5 lb•in)
RTB keying	None
Wire category <sup>(2)</sup>	2 - shielded input ports 2 - power ports 1 wire per terminal for each signal port
Wire size	
5069-RTB18-SPRING RTB	0.5...1.5 mm <sup>2</sup> (22...16 AWG) solid or stranded copper wire rated at 105 °C (221 °F), or greater, 2.9 mm (0.11 in.) max diameter including insulation
5069-RTB18-SCREW RTB	0.5...1.5 mm <sup>2</sup> (22...16 AWG) solid or stranded copper wire rated at 105 °C (221 °F), or greater, 3.5 mm (0.14 in.) max diameter including insulation
Insulation-stripping length	
5069-RTB18-SPRING RTB	10 mm (0.39 in.)
5069-RTB18-SCREW RTB	12 mm (0.47 in.)
Weight, approx	175 g (0.39 lb)
Inputs	Series A: 8 differential Series B: 8 single-ended
Input range, voltage	±10V 0...10V 0...5V
Input range, current	0...20 mA 4...20 mA
Input impedance	Voltage: >1 MΩ Current: 90 Ω typical, 70...110 Ω range

## Technical Specifications - 5069-IF8

Attribute	5069-IF8
Common mode voltage (channel to channel)	Series A: ±10V (Current mode) ±2V (Voltage mode) Series B: -
Module conversion method	Sigma-Delta, Two 24-bit multiplexed ADC
Resolution, voltage <sup>(3)</sup> (16 bits at 10 Hz notch filter)	±10.5V: <320 μV/count (15 bits plus sign bipolar) 0...10.5V: <160 μV/count (16 bits unipolar) 0...5.25V: <80 μV/count (16 bits unipolar)
Resolution, current <sup>(3)</sup> (16 bits at 10 Hz notch filter)	0...21 mA: <0.32 μA/count (16 bits) 3.6...21 mA: <0.27 μA/count (16 bits)
Calibrated accuracy at 77 °F (25 °C)	Voltage 0.10% full scale Current 0.10% full scale
Accuracy drift with temperature	Voltage 0.20% full scale Current 0.30% full scale
Input Total Unadjusted Error (TUE) <sup>(4)</sup> (Over full temperature range)	Voltage 0.30% full scale Current 0.40% full scale
Scan Time	
Per channel	625 μs
Per group (channel group 0...3 or channel group 4...7)	2.5 ms
Notch filter at minimum RPI (0.2 ms, 1 channel enabled)	62.5 kHz
Minimum notch filter frequency at RPI of 2.5 ms	10 kHz
Step response time to 63% of value (Notch filter 10 kHz)	7.5 ms
Input notch filter (Hz) selections	5, 10 (50/60 Default), 15, 20, 50, 60, 100, 200, 500, 1000, 2500, 5000, 10000, 15625, 25000, 31250, 62500
Input anti-aliasing filter cutoff frequency, nom	500 Hz
Input digital filter	First order lag, 0 ms (Default)...32,767 ms (32,767 s)
HART handheld compliance	Add an external 250 Ω resistor into the current loop for HART transmitter compliance.
Overvoltage protection, max	Voltage and Current modes: ± 30V DC
Overcurrent protection, max	Current mode: ±30 mA
Data value during overload condition	Full scale, overrange flag, Data uncertain/data bad
Open circuit detection time	Voltage: + full scale, < 2 s Current: 4...20 mA range, < 2 s
Onboard data alarming	Yes
Scaling to engineering units	Yes
Real-time channel sampling	Yes
Data format	IEEE 32-bit floating point

- (1) Level of Mod or SA power current that passes through the module depends on the system configuration, such as, module slot location and the other module types that are used in the system. For more information, see the controller user manuals in [Additional Resources on page 63](#).
- (2) Use this Conductor Category information to plan conductor routes. See the Industrial Automation Wiring and Grounding Guidelines, publication [1770-4.1](#).
- (3) Notch filter dependent.
- (4) Includes offset, gain, non-linearity, and repeatability error terms.

For **Certifications and Environmental Specifications**, see [page 26](#).

## 5069-IY4 and 5069-IY4K

### Analog Input Modules

The following table lists the analog devices that are supported with the 5069-IY4 and 5069-IY4K modules.

Supported Device	Modes <sup>(1)</sup>	Wiring Diagram Example Page
1-wire analog device	Current	30
2-wire analog device	Voltage	
4-wire analog device <sup>(2)</sup>	Any combination of current, voltage, RTD, Thermocouple <sup>(3)</sup>	31
2-wire RTD device	RTD	31
3-wire RTD device	Any combination of current, voltage, RTD, Thermocouple <sup>(3)</sup>	32
2-wire Thermocouple device	Thermocouple <sup>(4)</sup>	32
	Any combination of current, voltage, RTD, Thermocouple <sup>(3)</sup>	33

- (1) Make sure that the channel configuration in your Logix Designer application project matches the input device type that is connected to the channel. On the Module Properties dialog box, choose the input type in the Channels category. For example, if a current input device is connected to channel 0 on the module, the module configuration for channel 0 must be Input Type = Current.
- (2) These devices are 2-wire current and voltage devices with 2-wire sensor power connections.
- (3) You must use the 5069-RTB14CJC RTB if at least one thermocouple is connected to the module. If there are no thermocouples connected to the module, we recommend that you use the 5069-RTB18 RTB.
- (4) You must use the 5069-RTB14CJC RTB.

Current and Voltage Devices with Single-ended Transmitter Inputs Wiring

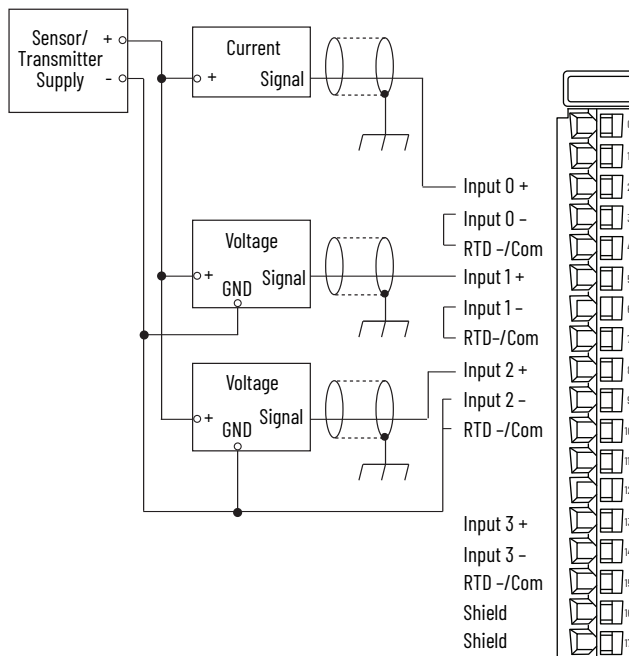

**Channel Connections** The diagram shows devices that are connected to channels 0, 1, and 2. You are not restricted to using only these channels. You can connect devices to any channel or combination of channels as needed.

**IMPORTANT**  
Remember the following:

- Use separate external power supplies to provide SA power to the system and to power external devices that are connected to the module.
- This module has only two shield terminals. Compact 5000 I/O module RTBs only support one wire per terminal.
- If you connect more than two devices to the module, you can ground two devices at the shield terminals. You must ground the remaining devices somewhere else, such as, to the DIN rail via a terminal strip. In this case, use the same power supply to power the additional devices. If separate power supplies are used to power the additional devices, ground the power supplies at the same ground location.

**SA Power** Connections to an external power supply that provides SA power are made via the SA power RTB on one of the following:

- CompactLogix 5380 controller
- Compact GuardLogix 5380 controller
- CompactLogix 5480 controller
- 5069-AENTR or 5069-AEN2TR EtherNet/IP Adapter
- 5069-FPD field potential distributor

**IMPORTANT**  
Remember the following:

- The 5069-IY4 and 5069-IY4K modules use DC SA power. You must connect DC power to the component, that is, the controller, adapter, or field potential distributor that provides SA power to the modules.
- If you install modules in a system that use AC SA power and DC SA power, you must install them on separate SA power buses.
- You use a 5069-FPD field potential distributor to establish a new SA power bus in a system. SA power buses are isolated from each other. To keep the modules on separate SA power buses, complete these steps.
  1. Install the modules that use one type of SA power, for example DC, to the right of the adapter or controller, that is, the first SA power bus.
  2. Install the 5069-FPD field potential distributor to establish a second SA power bus.
  3. Install the modules that use the other type of SA power, for example AC, on the second SA power bus.

**Current and Voltage Devices with Mixed Transmitter Inputs Wiring**

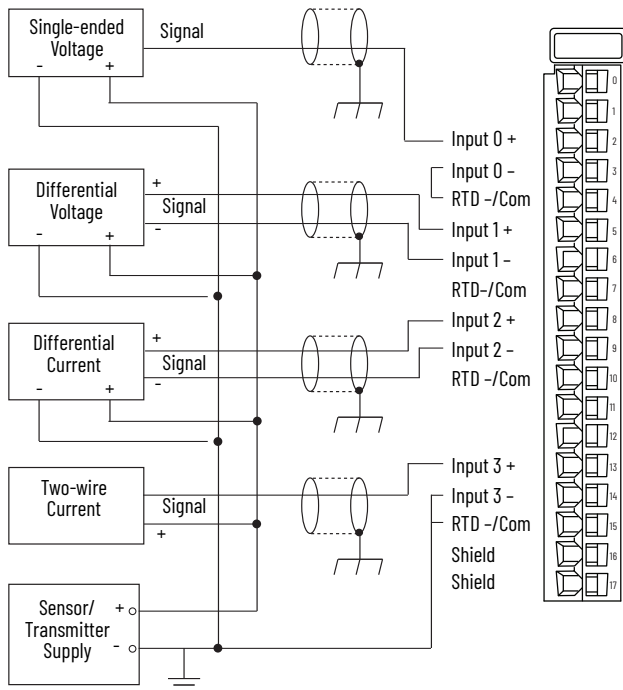

**Channel Connections** The diagram shows different devices that are connected to channels 0, 1, 2, and 3. You are not restricted to use all channels. You can connect devices to any channel or combination of channels as needed.

**IMPORTANT**  
Remember the following:

- Use separate external power supplies to provide SA power to the system and to power external devices that are connected to the module.
- This module has only two shield terminals. Compact 5000 I/O module RTBs only support one wire per terminal.
- If you connect more than two devices to the module, you can ground two devices at the shield terminals. You must ground the remaining devices somewhere else, such as, to the DIN rail via a terminal strip. In this case, use the same power supply to power the additional devices. If separate power supplies are used to power the additional devices, ground the power supplies at the same ground location.

**SA Power** Connections to an external power supply that provides SA power are made via the SA power RTB on one of the following:

- CompactLogix 5380 controller
- Compact GuardLogix 5380 controller
- CompactLogix 5480 controller
- 5069-AENTR or 5069-AEN2TR EtherNet/IP Adapter
- 5069-FPD field potential distributor

**IMPORTANT**  
Remember the following:

- The 5069-IY4 and 5069-IY4K modules use DC SA power. You must connect DC power to the component, that is, the controller, adapter, or field potential distributor that provides SA power to the modules.
- If you install modules in a system that use AC SA power and DC SA power, you must install them on separate SA power buses.
- You use a 5069-FPD field potential distributor to establish a new SA power bus in a system. SA power buses are isolated from each other. To keep the modules on separate SA power buses, complete these steps.
  1. Install the modules that use one type of SA power, for example DC, to the right of the adapter or controller, that is, the first SA power bus.
  2. Install the 5069-FPD field potential distributor to establish a second SA power bus.
  3. Install the modules that use the other type of SA power, for example AC, on the second SA power bus.

**RTD Devices with Three Wires - Input Wiring**

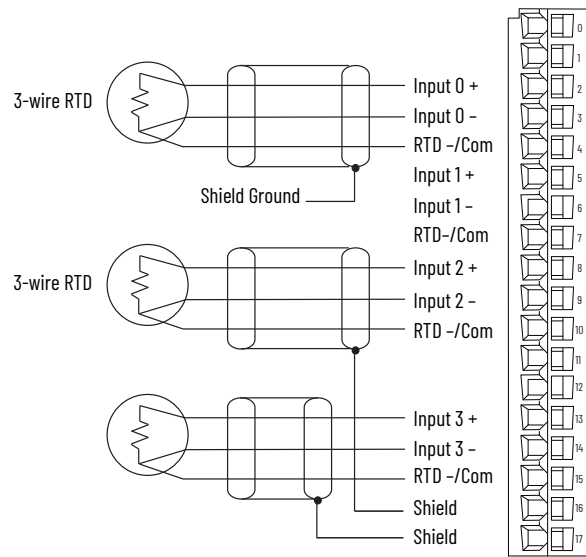

**Channel Connections** The diagram shows devices that are connected to channels 0, 2, and 3. You are not restricted to using only these channels. You can connect devices to any channel or combination of channels as needed.

**IMPORTANT**  
This module has only two shield terminals. Compact 5000 I/O module RTBs only support one wire per terminal. If you connect more than two devices to the module, you can ground two devices at the shield terminals. You must ground the remaining devices somewhere else, such as, to the DIN rail via a terminal strip.

**RTD Devices with Two Wires - Input Wiring**

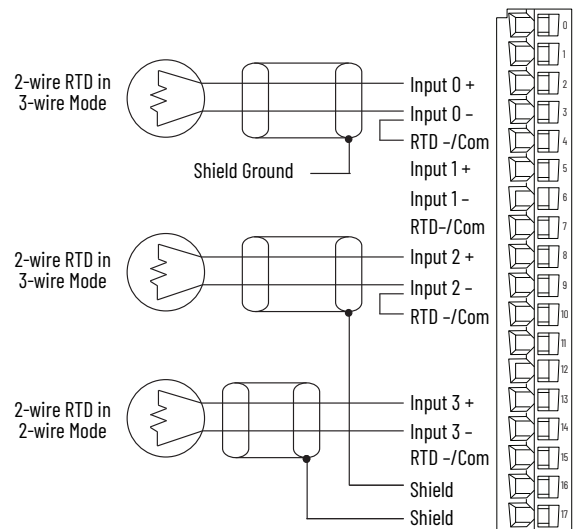

**Channel Connections** The diagram shows a device that is connected to channels 0, 2, and 3. You are not restricted to using only these channels. You can connect devices to any channel or combination of channels as needed.

**IMPORTANT**  
Remember the following:

- When you use a 2-wire RTD in 3-wire mode, as shown on the RTDs that are connected to channel 3, you must jumper terminals Input x- and RTD x together.
- This module has only two shield terminals. Compact 5000 I/O module RTBs only support one wire per terminal.
- If you connect more than two devices to the module, you can ground two devices at the shield terminals. You must ground the remaining devices somewhere else, such as, to the DIN rail via a terminal strip.

**Current, Voltage, and RTD Devices - Input Wiring**

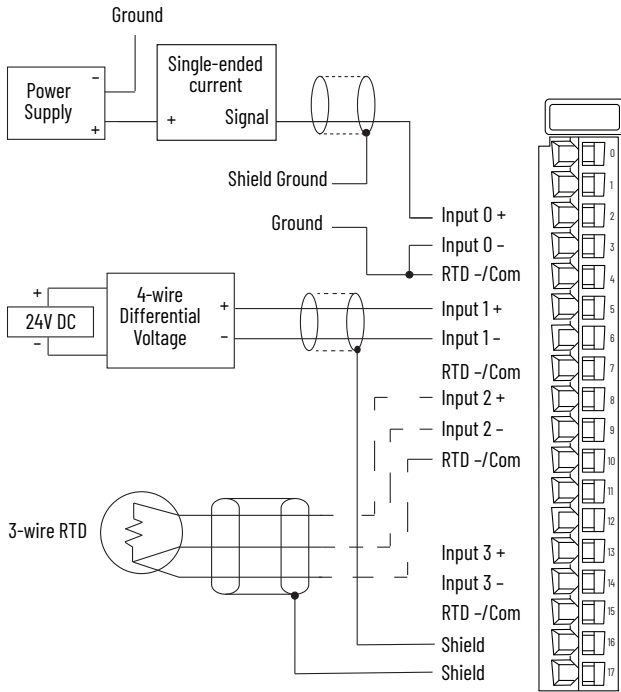

**Thermocouple Device - Input Wiring**

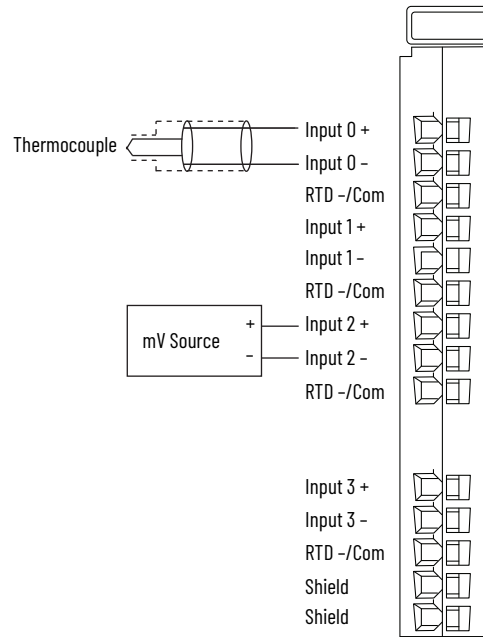

**Channel Connections** The diagram shows an analog current device connected to channel 0, an analog voltage device connected to channel 1, and an RTD connected to channel 2. You are not restricted to using those devices with those channels. You can connect devices to any channel or combination of channels as needed.

**IMPORTANT**  
Remember the following:

- In this example, the module can use a 5069-RTB18 RTB because thermocouple devices are not connected to the module.
- Use separate external power supplies to provide SA power to the system and to power external devices that are connected to the module.
- This module has only two shield terminals. Compact 5000 I/O module RTBs only support one wire per terminal.
- If you connect more than two devices to the module, you can ground two devices at the shield terminals. You must ground the remaining devices somewhere else, such as, to the DIN rail via a terminal strip. In this case, use the same power supply to power the additional devices. If separate power supplies are used to power the additional devices, ground the power supplies at the same ground location.

**SA Power** Connections to an external power supply that provides SA power are made via the SA power RTB on one of the following:

- CompactLogix 5380 controller
- CompactLogix 5480 controller
- Compact GuardLogix 5380 controller
- 5069-AENTR or 5069-AEN2TR EtherNet/IP Adapter
- 5069-FPD field potential distributor

**IMPORTANT**  
Remember the following:

- The 5069-IY4 and 5069-IY4K modules use DC SA power. You must connect DC power to the component, that is, the controller, adapter, or field potential distributor that provides SA power to the modules.
- If you install modules in a system that use AC SA power and DC SA power, you must install them on separate SA power buses.
- You use a 5069-FPD field potential distributor to establish a new SA power bus in a system. SA power buses are isolated from each other. To keep the modules on separate SA power buses, complete these steps.
  - Install the modules that use one type of SA power, for example DC, to the right of the adapter or controller, that is, the first SA power bus.
  - Install the 5069-FPD field potential distributor to establish a second SA power bus.
  - Install the modules that use the other type of SA power, for example AC, on the second SA power bus.

**Channel Connections** The diagram shows different devices that are connected to channels 0 and 2. You are not restricted to using only these channels. You can connect devices to any channel or combination of channels as needed.

**IMPORTANT**  
When you use the 5069-IY4 and 5069-IY4K analog input modules in Thermocouple mode, you must use one of these CJC type RTBs:

- 5069-RTB14CJC-SPRING (shown)
- 5069-RTB14CJC-SCREW



**Current, Voltage, RTD, and Thermocouple Devices - Input Wiring**

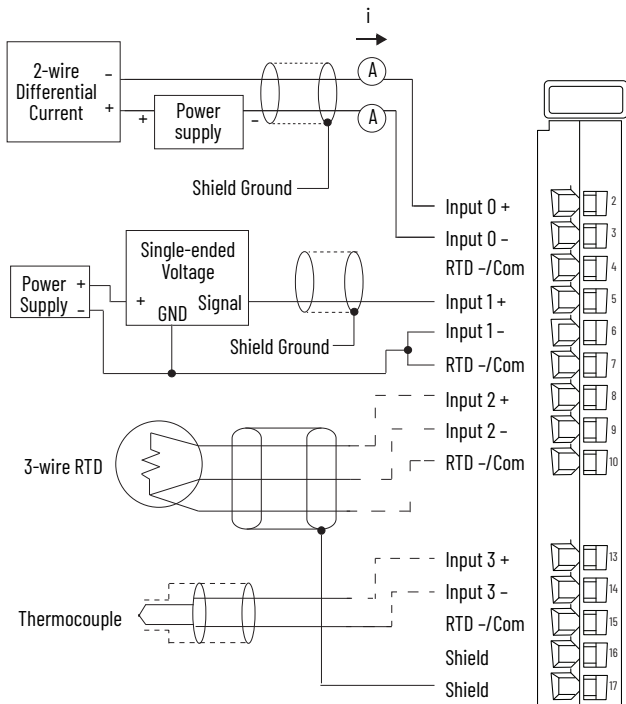

**IMPORTANT**

In this example, the module uses a 5069-RTB14CJC RTB because a thermocouple is connected to the module.

**Channel Connections**

The diagram shows different devices that are connected to channels 0, 1, 2, and 3, respectively. You are not required to use all channels. You can connect devices to any channel or combination of channels as needed.

**IMPORTANT**

Remember the following:

- When an analog current device is connected to the module, place additional loop devices, for example, strip chart recorders, at either **A** location in the current loop.
- Use separate external power supplies to provide SA power to the system and to power external devices that are connected to the module.
- This module has only two shield terminals. Compact 5000 I/O module RTBs only support one wire per terminal.
- If you connect more than two devices to the module, you can ground two devices at the shield terminals. You must ground the remaining devices somewhere else, such as, to the DIN rail via a terminal strip. In this case, use the same power supply to power the additional devices. If separate power supplies are used to power the additional devices, ground the power supplies at the same ground location.

**SA Power**

Connections to an external power supply that provides SA power are made via the SA power RTB on one of the following:

- CompactLogix 5380 controller
- CompactLogix 5480 controller
- Compact GuardLogix 5380 controller
- 5069-AENTR or 5069-AEN2TR EtherNet/IP Adapter
- 5069-FPD field potential distributor

**IMPORTANT**

Remember the following:

- The 5069-IY4 and 5069-IY4K modules use DC SA power. You must connect DC power to the component, that is, the controller, adapter, or field potential distributor that provides SA power to the modules.
- If you install modules in a system that use AC SA power and DC SA power, you must install them on separate SA power buses.
- You use a 5069-FPD field potential distributor to establish a new SA power bus in a system. SA power buses are isolated from each other. To keep the modules on separate SA power buses, complete these steps.
  1. Install the modules that use one type of SA power, for example DC, to the right of the adapter or controller, that is, the first SA power bus.
  2. Install the 5069-FPD field potential distributor to establish a second SA power bus.
  3. Install the modules that use the other type of SA power, for example AC, on the second SA power bus.

**Functional Block Diagram - Current Mode, Voltage Mode, and Mixed Transmitter Inputs**

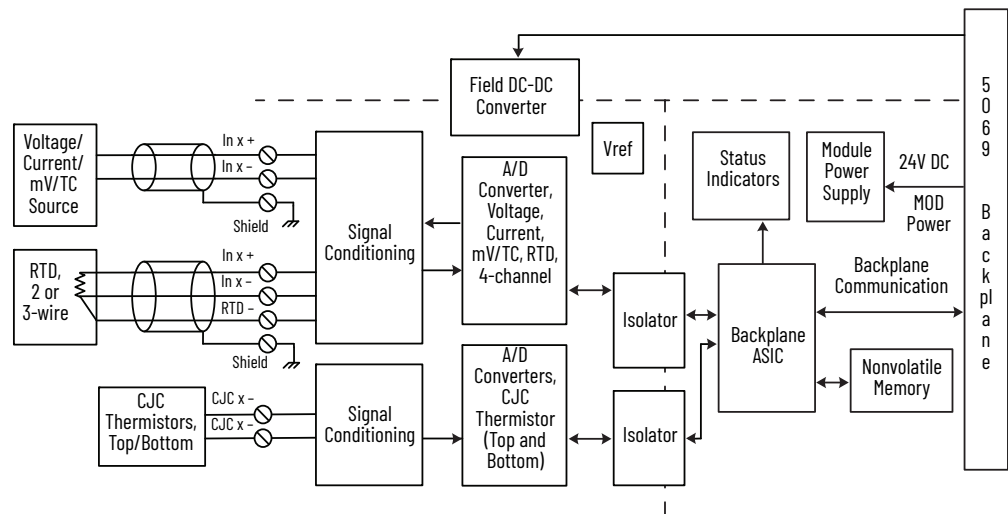

Technical Specifications - 5069-IY4 and 5069-IY4K

Attribute	5069-IY4, 5069-IY4K
Voltage and current ratings	
MOD power	75 mA @ 18...32V DC
MOD power (passthrough) <sup>(1)</sup>	9.55 A @ 18...32V DC
SA power	100 mA @ 18...32V DC
SA power (passthrough) <sup>(1)</sup>	9.95 A @ 18...32V DC
Do not exceed 10 A MOD or SA power (passthrough) current draw	
Power dissipation, max	Voltage mode: 1.8 W Current mode: 2.1 W RTD mode: 2.1 W Thermocouple / millivolt mode: 1.8 W
Thermal dissipation, max	Voltage mode: 6.1 BTU/hr Current mode: 7.2 BTU/hr RTD mode: 7.2 BTU/hr Thermocouple/millivolt: 6.1 BTU/hr
Isolation voltage	250V (continuous), Basic Insulation Type 50V Functional Isolation between SA power and input ports No isolation between individual input ports
Calibration methods	Factory calibrated User-performed (optional)
Module keying	Electronic keying via programming software
Indicators	1 green/red module status indicator 4 yellow/red I/O status indicators 2 yellow/red CJC status indicators
Slot width	1
Common mode noise rejection ratio	130 dB @ 50/60 Hz
Normal mode noise rejection ratio	65 dB @ 50/60 Hz, notch filter dependent
Dimensions (HxWxD), approx	144.57 x 22 x 105.42 mm (5.69 x 0.87 x 4.15 in.)
DIN rail	Compatible zinc-plated chromate-passivated steel DIN rail. You can use the EN50022 - 35 x 7.5 mm (1.38 x 0.30 in.) DIN rail.
RTB	One of these RTB types. • 5069-RTB18-SCREW • 5069-RTB18-SPRING • 5069-RTB14CJC-SCREW (Thermocouple mode) • 5069-RTB14CJC-SPRING (Thermocouple mode) <b>IMPORTANT:</b> You must order RTBs separately. RTBs do not ship with Compact 5000 I/O modules. We recommend that you order only the RTB type that your system requires.
RTB torque (5069-RTB18-SCREW, 5069-RTB14CJC-SCREW)	0.4 N•m (3.5 lb•in)
RTB keying	None
Wire category <sup>(2)</sup>	2 - shielded input ports 2 - power ports 1 wire per terminal for each signal port
Wire size	
5069-RTB18-SPRING and 5069-RTB14CJC-SPRING RTBs	0.5...1.5 mm <sup>2</sup> (22...16 AWG) solid or stranded shielded copper wire rated at 105 °C (221 °F), or greater, 2.9 mm (0.11 in.) max diameter including insulation, single wire connection only.
5069-RTB18-SCREW and 5069-RTB14CJC-SCREW RTBs	0.5...1.5 mm <sup>2</sup> (22...16 AWG) solid or stranded shielded copper wire rated at 105 °C (221 °F), or greater, 3.5 mm (0.14 in.) max diameter including insulation, single wire connection only.

Technical Specifications - 5069-IY4 and 5069-IY4K

Attribute	5069-IY4, 5069-IY4K
Insulation-stripping length	
5069-RTB18-SPRING RTB	10 mm (0.39 in.)
5069-RTB18-SCREW RTB	12 mm (0.47 in.)
Weight, approx	175 g (0.39 lb)
North American temperature code	T4
UKEX/ATEX temp code	T4
IECEx temp code	T4
Inputs	4 differential
Input range, voltage	±10V 0...10V 0...5V
Input range, current	0...20 mA 4...20 mA
Input range, resistive	1...500 Ω 2...1000 Ω 4...2000 Ω 8...4000 Ω
Input type, RTD	100, 200, 500, 1000 Ω platinum, alpha=385 100, 200, 500, 1000 Ω platinum, alpha=3916 120 Ω nickel, alpha=672 100, 120, 200, 500 Ω nickel, alpha=618 10 Ω copper 427
Input range, thermocouple / millivolt	±100 mV
Input type, thermocouple	B, C, D, E, J, K, L (TXK/XK), N, R, S, T
Input impedance	Voltage: >1 MΩ Current: 90 Ω typical, 70...110 Ω range RTD: >1 MΩ Thermocouple/millivolt: >1 MΩ
Common mode voltage (channel to channel)	±10V (Current mode and 3-wire RTD mode) ±2V (Voltage mode)
Module conversion method	Sigma-Delta, One 24-bit multiplexed ADC
Resolution, voltage <sup>(3)</sup> (16 bits at 10 Hz notch filter)	±10.5V: <320 μV/count (15 bits plus sign bipolar) 0...10.5V: <160 μV/count (16 bits unipolar) 0...5.25V: <80 μV/count (16 bits unipolar)
Resolution, current <sup>(3)</sup> (16 bits at 10 Hz notch filter)	0...21 mA: <0.32 μA/count (16 bits) 3.6...21 mA: <0.27 μA/count (16 bits)
Resolution, RTD <sup>(3)</sup> (16 bits at 10 Hz notch filter) 3 Wire mode	< 7.9 mΩ/cnt in 1...500 Ω mode < 15.8 mΩ/cnt in 2...1000 Ω mode < 31.7 mΩ/cnt in 4...2000 Ω mode < 63.4 mΩ/cnt in 8...4000 Ω mode
Resolution, thermocouple / millivolt <sup>(3)</sup> (16 bits at 10 Hz notch filter)	< 3.1 μV/cnt in ±100 mV mode
RTD excitation current	600 μA, 3 wire mode 100 μA, 2 wire mode
Wire impedance (3-wire RTD mode only)	25 Ω maximum for specified accuracy

## Technical Specifications - 5069-IY4 and 5069-IY4K

Attribute	5069-IY4, 5069-IY4K
RTD sensor types:	Supported temperature ranges:
100, 200, 500, 1000 Ohm PT 385	-200...+870 °C (-328...+1598 °F) 73...1143 °K (132...2058 °R)
100, 200, 500, 1000 Ohm PT 3916	-200...+630 °C (-328...+1166 °F) 73...903 °K (132...1626 °R)
10 Ohm CU 247	-200...+260 °C (-328...+500 °F) 73...533 °K (132...960 °R)
120 Ohm NI 672	-80...+320 °C (-112...+608 °F) 193...593 °K (348...1068 °R)
100, 120, 200, 500 Ohm NI 618	-60...+250 °C (-76...+482 °F) 213...523 °K (384...942 °R)
Thermocouple type:	Supported temperature ranges:
Thermocouple Type B	21...1820 °C (68...3308 °F) 293...2093 °K (528...3768 °R)
Thermocouple Type C	0...2320 °C (32...4208 °F) 273...2593 °K (492...4668 °R)
Thermocouple Type D	
Thermocouple Type E	-270...+1000 °C (-454...+1832 °F) 3...1273 °K (6...2292 °R)
Thermocouple Type J	-210...+1200 °C (-346...+2192 °F) 63...1473 °K (114...2652 °R)
Thermocouple Type K	-270...+1372 °C (-454...+2502 °F) 3...1645 °K (6...2961 °R)
Thermocouple Type N	-270...+1300 °C (-454...+2372 °F) 3...1573 °K (6...2832 °R)
Thermocouple Type R	-50...+1768 °C (-58...+3215 °F) 223...2041 °K (402...3674 °R)
Thermocouple Type S	
Thermocouple Type T	-270...+400 °C (-454...+752 °F) 3...673 °K (6...1212 °R)
Thermocouple Type TXK/XK (L)	-200...+800 °C (-328...+1472 °F) 73...1073 °K (132...1932 °R)
Thermocouple linearization	ITS-90
CJC inputs (for thermocouple mode use only)	Two CJC sensors 2 thermistors embedded in 5069-RTB14CJC-SCREW or 5069-RTB14CJC-SPRING RTB -or- 2 thermistors wired to 5069-RTB18-SCREW or 5069- RTB18-5069-RTB18-SPRING RTB Thermistor type: Measurement Specialties, Inc. 10K3A1A
Local CJC sensor accuracy	±32.54 °F (±0.3 °C)
Remote CJC sensor accuracy (Based on specified thermistor)	±32.54 °F (±0.3 °C)
Calibrated accuracy at 77 °F (25 °C)	Voltage 0.100% full scale Current 0.100% full scale RTD 0.100% full scale Thermocouple/millivolt 0.100% full scale
Accuracy drift with temperature	Voltage 0.200% full scale Current 0.300% full scale RTD 0.200% full scale Thermocouple/millivolt 0.200% full scale
Input Total Unadjusted Error (TUE) <sup>(4)</sup> (Over full temperature range)	Voltage 0.300% Full Scale Current 0.400% Full Scale RTD 0.300% Full Scale Thermocouple/millivolt 0.300% Full Scale

## Technical Specifications - 5069-IY4 and 5069-IY4K

Attribute	5069-IY4, 5069-IY4K
Scan time	625 µs
• Per channel	2.5 ms
• Per group (channel group 0...3)	
Notch filter at minimum RPI (0.2 ms, 1 channel enabled)	62.5 kHz
Minimum notch filter frequency at RPI of 2.5 ms	10 kHz
Step response time to 63% of value (Notch filter 10 kHz)	7.5 ms
Input notch filter (Hz) selections	5, 10 (50/60 default), 15, 20, 50, 60, 100, 200, 500, 1000, 2500, 5000, 10000, 15625, 25000, 31250, 62500
Input anti-aliasing filter cutoff frequency, typical	500 Hz
Input digital filter	First Order Lag, 0 ms (Default)...32,767 ms (32.767 s)
HART handheld compliance:	Add an external 250 Ω resistor into the current loop for HART transmitter compliance.
Overvoltage protection, max	Voltage, current, RTD, and thermocouple/mV modes: ± 30V DC
Overcurrent protection, max	Current mode: ± 30 mA
Data value during overload condition	Full scale, overrange flag, Data uncertain / data bad
Open circuit detection time, nom	Voltage: + full scale, < 2 s Current: 4...20 mA range, < 2 s RTD: < 2 s Thermocouple / millivolt: + full scale, < 10 s
Onboard data alarming	Yes
Scaling to engineering units	Yes
Real-time channel sampling	Yes
Data format	IEEE 32-bit floating point

- (1) Level of Mod or SA power current that passes through the module depends on the system configuration, such as, module slot location and the other module types that are used in the system. For more information, see the controller user manuals in [Additional Resources on page 63](#).
- (2) Use this Conductor Category information to plan conductor routes. See the Industrial Automation Wiring and Grounding Guidelines, publication [1770-4.1](#).
- (3) Notch filter dependent.
- (4) Includes offset, gain, non-linearity, and repeatability error terms.

For **Certifications and Environmental Specifications**, see [page 26](#).

## 5069-OF4, 5069-OF4K, and 5069-OF8

### Analog Current/Voltage Output Modules

5069-OF4 and 5069-OF4K Current Mode - Output Wiring

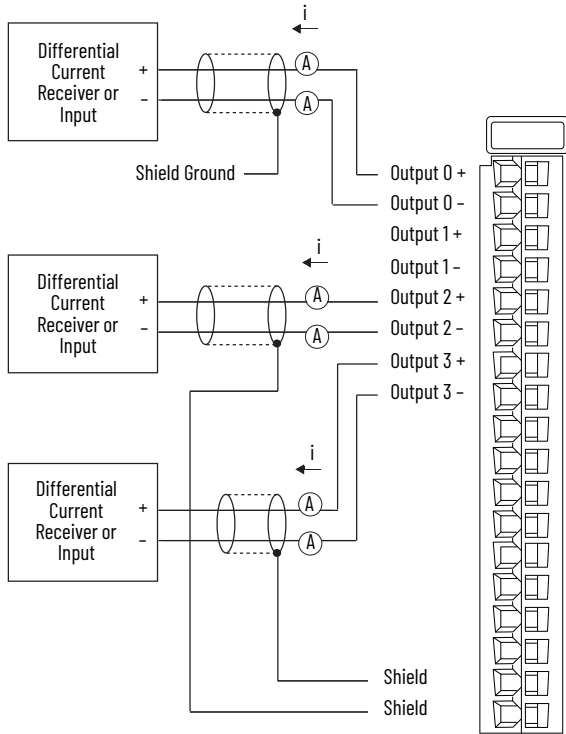

5069-OF8 Current Mode - Output Wiring

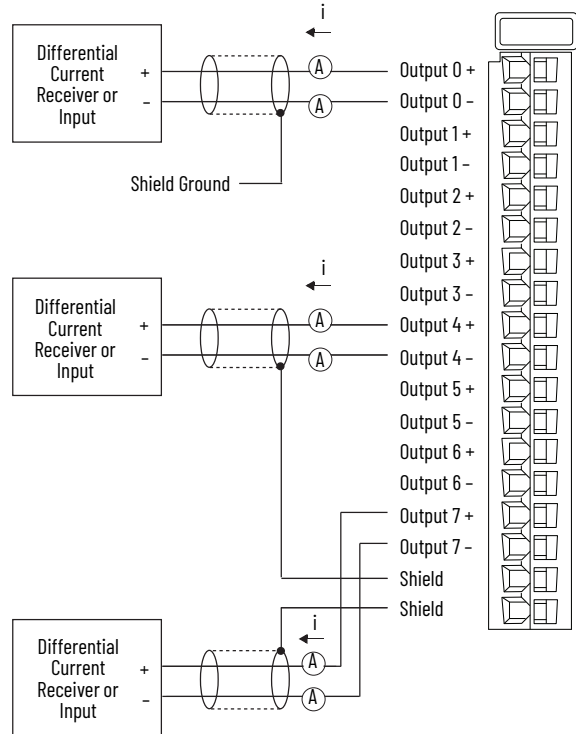

**Channel Connections** The diagram shows a device that is connected to channels 0, 2, and 3. You aren't restricted to using only these channels. You can connect devices to any channel or combination of channels as needed.

- IMPORTANT:**
- Place more loop devices, for example, strip chart recorders, at either **A** location in the current loop.
  - This module has only two shield terminals. Compact 5000 I/O module RTBs only support one wire per terminal.
  - If you connect more than two devices to the module, you can ground two devices at the shield terminals. You must ground the remaining devices somewhere else, such as, to the DIN rail via a terminal strip

**SA Power** Connections to an external power supply that provides SA power are made via the SA power RTB on one of the following:

- CompactLogix 5380 controller
- CompactLogix 5480 controller
- Compact GuardLogix 5380 controller
- 5069-AENTR or 5069-AEN2TR EtherNet/IP Adapter
- 5069-FPD field potential distributor

- IMPORTANT**
- Remember the following:
- The 5069-OF4 module uses DC SA power. You must connect DC power to the component, that is, the controller, adapter, or field potential distributor that provides SA power to the modules.
  - If you install modules in a system that use AC SA power and DC SA power, you must install them on separate SA power buses.
  - You use a 5069-FPD field potential distributor to establish a new SA power bus in a system. SA power buses are isolated from each other. To keep the modules on separate SA power buses, complete these steps.
    - Install the modules that use one type of SA power, for example DC, to the right of the adapter or controller, that is, the first SA power bus.
    - Install the 5069-FPD field potential distributor to establish a second SA power bus.
    - Install the modules that use the other type of SA power, for example AC, on the second SA power bus.

**Channel Connections** The diagram shows devices that are connected to channels 0, 4, and 7. You aren't restricted to using only those channels. You can connect devices to any channel or combination of channels as needed.

- IMPORTANT:**
- Place more loop devices, for example, strip chart recorders, at either **A** location in the current loop.
  - This module has only two shield terminals. Compact 5000 I/O module RTBs only support one wire per terminal.
  - If you connect more than two devices to the module, you can ground two devices at the shield terminals. You must ground the remaining devices somewhere else, such as, to the DIN rail via a terminal strip

**5069-OF4 and 5069-OF4K Voltage Mode - Output Wiring**

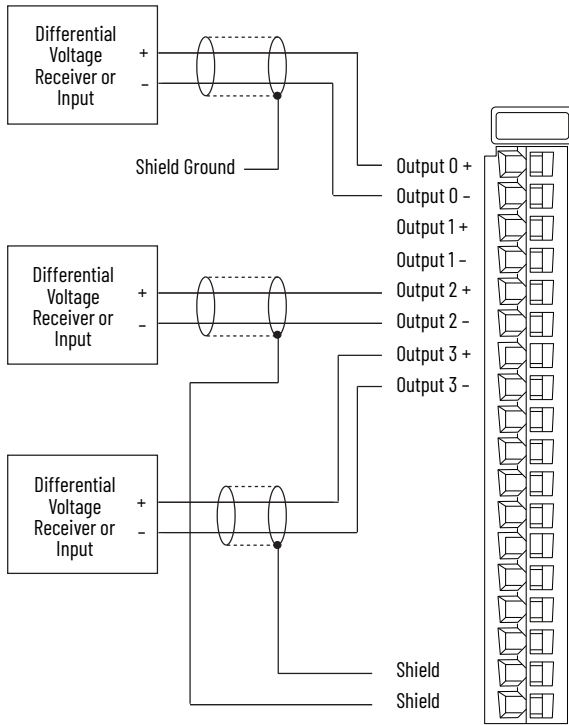

**5069-OF8 Voltage Mode - Output Wiring**

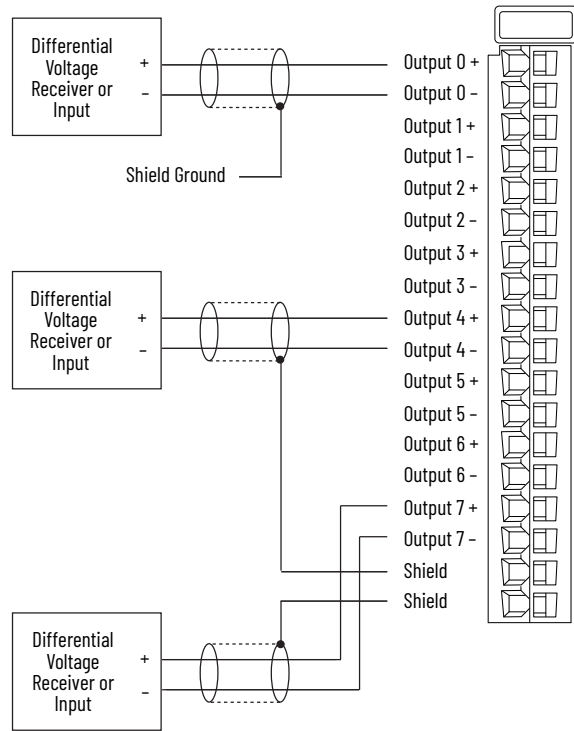

**Channel Connections** The diagram shows a device that is connected to channels 0, 2, and 3. You aren't restricted to using only these channels. You can connect devices to any channel or combination of channels as needed.

**IMPORTANT:**

- This module has only two shield terminals. Compact 5000 I/O module RTBs only support one wire per terminal.
- If you connect more than two devices to the module, you can ground two devices at the shield terminals. You must ground the remaining devices somewhere else, such as, to the DIN rail via a terminal strip

**Channel Connections** The diagram shows a device that is connected to channels 0, 2, and 3. You aren't restricted to using only these channels. You can connect devices to any channel or combination of channels as needed.

**IMPORTANT:**

- This module has only two shield terminals. Compact 5000 I/O module RTBs only support one wire per terminal.
- If you connect more than two devices to the module, you can ground two devices at the shield terminals. You must ground the remaining devices somewhere else, such as, to the DIN rail via a terminal strip

**Functional Block Diagram - 5069-OF4, 5069-OF4K**

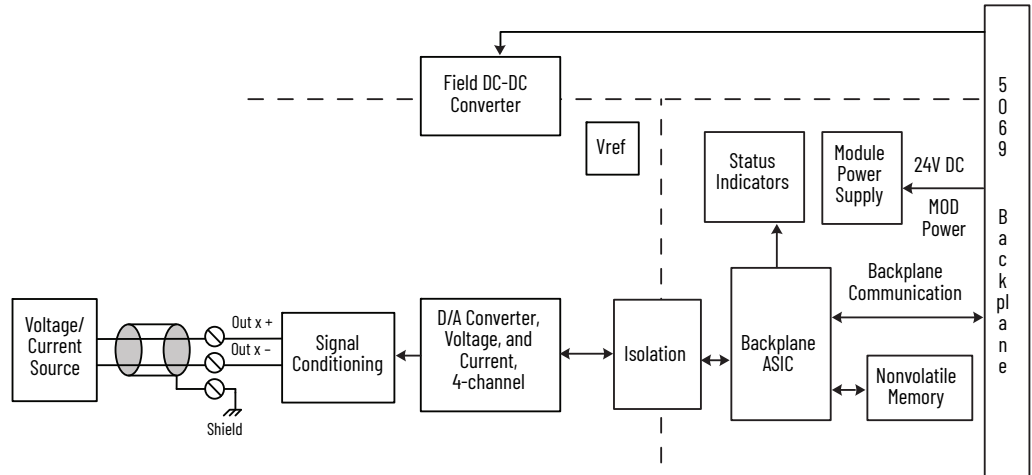

## Technical Specifications - 5069-0F4, 5069-0F4K, 5069-0F8

Attribute	5069-0F4, 5069-0F4K	5069-0F8
Voltage and current ratings		
Analog output ratings	+/-10V DC, 0...20 mA per channel	
MOD power	75 mA @ 18...32V DC	
MOD power (passthrough) <sup>(1)</sup>	9.55 A @ 18...32V DC	
SA power	150 mA @ 18...32V DC	250 mA @ 18...32V DC
SA power (passthrough) <sup>(1)</sup>	9.95 A @ 18...32V DC	
Power dissipation, max	3.3 W	5.3 W
Thermal dissipation, max	11.3 BTU/hr	18.1 BTU/hr
Isolation voltage	250V (continuous), Basic Insulation Type 50V Functional Isolation between SA power and output ports No isolation between individual output ports	
Calibration methods	Factory Calibrated User-performed (optional)	
Module keying	Electronic keying via programming software	
Indicators	1 green/red module status indicator 4 yellow/red I/O status indicators	1 green/red module status indicator 8 yellow/red I/O status indicators
Slot width	1	
Dimensions (HxWxD), approx	144.57 x 22 x 105.42 mm (5.69 x 0.87 x 4.15 in.)	
DIN rail	Compatible zinc-plated chromate-passivated steel DIN rail. You can use the EN50022 - 35 x 7.5 mm (1.38 x 0.30 in.) DIN rail.	
RTB	One of these RTB types. • 5069-RTB18-SPRING RTB • 5069-RTB18-SCREW RTB <b>IMPORTANT:</b> You must order RTBs separately. RTBs do not ship with Compact 5000 I/O modules. We recommend that you order only the RTB type that your system requires.	
RTB torque (5069-RTB18-SCREW RTB only)	0.4 N•m (3.5 lb•in)	
RTB keying	None	
Wire category <sup>(2)</sup>	2 - shielded input ports 2 - power ports 1 wire per terminal for each signal port	
Wire size		
5069-RTB18-SPRING RTB	0.5...1.5 mm <sup>2</sup> (22...16 AWG) solid or stranded copper wire rated at 105 °C (221 °F), or greater, 2.9 mm (0.11 in.) max diameter including insulation	
5069-RTB18-SCREW RTB	0.5...1.5 mm <sup>2</sup> (22...16 AWG) solid or stranded copper wire rated at 105 °C (221 °F), or greater, 3.5 mm (0.14 in.) max diameter including insulation	
Insulation-stripping length		
5069-RTB18-SPRING RTB	10 mm (0.39 in.)	
5069-RTB18-SCREW RTB	12 mm (0.47 in.)	

## Technical Specifications - 5069-0F4, 5069-0F4K, 5069-0F8

Attribute	5069-0F4, 5069-0F4K	5069-0F8
Weight, approx	175 g (0.39 lb)	
Outputs	4 voltage or current	8 voltage or current
Output range, voltage	± 10V 0...10V 0...5V	
Output range, current	0...20 mA 4...20 mA	
Resolution	16 bits across ± 10.5V - 320 µV/bit 16 bits across 10.5V - 160 µV/bit 16 bits across 5.25V - 80 µV/bit 16 bits across 21 mA - 320 nA/bit	
Drive capability	Voltage - 1000 Ω min Current - 500 Ω max	
Capacitive load, max (voltage mode only)	1 µF	
Inductive load, max (current mode only)	1 mH	
Open circuit detection	Current mode only	
Short circuit detection	Voltage mode only - output electronically limited to 16 mA or less	
Data format	IEEE 32-bit floating point	
Module conversion method	R-Ladder DAC, monotonicity with no missing codes	
Conversion time per channel	25 µs	
Scan time	Per group 0...3: 1.0 ms For 5069-0F8 only: Per group 0...7: 2.0 ms	
Step response time to 63% of value	Voltage mode - 18 µs max Current mode - 1 ms max	
Overvoltage protection, max	± 32V DC	
Repeatability	0.05%	
Calibrated accuracy at 25 °C (77 °F)	Voltage - 0.10% full scale Current - 0.10% full scale	
Accuracy drift with temperature	Voltage - 0.30% full scale Current - 0.50% full scale	

(1) Level of Mod or SA power current that passes through the module depends on the system configuration, such as, module slot location and the other module types that are used in the system. For more information, see the controller user manuals in [Additional Resources on page 63](#).

(2) Use this Conductor Category information to plan conductor routes. See the Industrial Automation Wiring and Grounding Guidelines, publication [1770-4.1](#).

For **Certifications and Environmental Specifications**, see [page 26](#).

## Safety I/O Modules

The following safety modules are available.

I/O Type	Cat. No.	Description	Page
DC safety sinking input	5069-IB8S	18...32V DC 8-point, safety sinking input module	40
	5069-IB8SK	18...32V DC 8-point, conformal coated safety sinking input module	
DC safety output	5069-OBV8S	18...32V DC 8-point, safety output module that can be used as a Bipolar output module or sourcing output module	43
	5069-OBV8SK	18...32V DC 8-point, conformal coated safety output module that can be used as a Bipolar output module or sourcing output module	

### Certifications - Safety I/O Modules

Certification <sup>(1)</sup>	5069-IB8S, 5069-IB8SK, 5069-OBV8S, 5069-OBV8SK
c-UL-us	UL Listed Industrial Control Equipment, certified for US and Canada. See UL File E322657. UL Listed for Class I, Division 2 Group A,B,C,D Hazardous Locations, certified for U.S. and Canada. See UL File E334470.
UKCA and CE	UK Statutory Instrument 2016 No. 1091 and European Union 2014/30/EU EMC Directive, compliant with: EN 61326-1; Meas./Control/Lab., Industrial Requirements EN 61000-6-2; Industrial Immunity EN 61000-6-4; Industrial Emissions EN 61131-2; Programmable Controllers (Clause 8, Zone A & B)  UK Statutory Instrument 2008 No. 1597 and European Union 2006/42/EC MD, compliant with: EN 60204-1; Electrical equipment of machines EN ISO 13849-1; Safety-related parts of control systems EN 62061; Functional safety of safety-related control systems Cat. 4/PLe according to EN ISO 13849-1, and SIL 3 according to EN 62601/IEC 61508/IEC 62511  UK Statutory Instrument 2012 No. 3032 and European Union 2011/65/EU RoHS, compliant with: EN IEC 63000; Technical documentation
RCM	Australian Radiocommunications Act, compliant with: EN 61000-6-4; Industrial Emissions
Ex	UK Statutory Instrument 2016 No. 1107 and European Union 2014/34/EU ATEX Directive, compliant with: EN IEC 60079-0; General Requirements EN IEC 60079-7; Explosive Atmospheres, Protection "e" II 3 G Ex ec IIC T4 Gc DEMKO 18 ATEX 2019X and UL22UKEX2496
IECEX	IECEX System, compliant with: IEC 60079-0; General Requirements IEC 60079-7; Explosive Atmospheres, Protection "e" II 3 G Ex ec IIC T4 Gc IECEX UL 18.0014X
TÜV	TÜV Certified for Functional Safety; <sup>(2)</sup> Capable of SIL 3, CAT. 4/PLe
KC	Korean Registration of Broadcasting and Communications Equipment, compliant with: Article 58-2 of Radio Waves Act, Clause 3
Morocco	Arrêté ministériel n° 6404-15 du 1 er muharram 1437 Arrêté ministériel n° 6404-15 du 29 ramadan 1436
CCC	CNCA-C23-01:2019 强制性产品认证实施规则 防爆电气 CNCA-C23-01:2019 CCC Implementation Rule Explosion-Proof Electrical Products CCC: 2020122309111301 and 2021122309113957

- (1) When marked. See the Product Certification link at [rok.auto/certifications](http://rok.auto/certifications) for Declarations of Conformity, Certificates, and other certification details.  
(2) When used with specified firmware revisions. See the Product Safety Certificate at [rok.auto/certifications](http://rok.auto/certifications) for a full list of safety-related certifications.

### Environmental Specifications - Safety I/O Modules

Attribute	5069-IB8S, 5069-IB8SK, 5069-OBV8S, 5069-OBV8SK
Temperature, operating IEC 60068-2-1 (Test Ad, Operating Cold) IEC 60068-2-2 (Test Bd, Operating Dry Heat) IEC 60068-2-14 (Test Nb, Operating Thermal Shock)	0 °C ≤ Ta ≤ +60 °C (+32 °F ≤ Ta ≤ +140 °F)
Temperature, surrounding air, maximum System mounted in horizontal orientation System mounted in any orientation other than horizontal (module derating) <sup>(1)</sup>	60 °C (140 °F) 50 °C (122 °F)
Temperature, nonoperating IEC 60068-2-1 (Test Ab, Unpackaged Nonoperating Cold) IEC 60068-2-2 (Test Bb, Unpackaged Nonoperating Dry Heat) IEC 60068-2-14 (Test Na, Unpackaged Nonoperating Thermal Shock)	-40...+85 °C (-40...+185 °F)
Relative humidity IEC 60068-2-30 (Test Db, Unpackaged Damp Heat)	5...95% noncondensing
Vibration IEC 60068-2-6 (Test Fc, Operating)	5 g @ 10...500 Hz
Shock, operating IEC 60068-2-27 (Test Ea, Unpackaged Shock)	30 g
Shock, nonoperating IEC 60068-2-27 (Test Ea, Unpackaged Shock)	50 g
Emissions	IEC 61000-6-4
ESD immunity IEC 61000-4-2	6 kV contact discharges 8 kV air discharges
Radiated RF immunity IEC 61000-4-3	20V/m with 1 kHz sine wave 80% AM from 80...6000 MHz
EFT/B immunity IEC 61000-4-4	±4 kV @ 5 kHz on signal ports
Surge transient immunity IEC 61000-4-5	±1 kV line-line (DM) and ±2 kV line-earth (CM) on signal ports
Conducted RF immunity IEC 61000-4-6	20V rms with 1 kHz sine wave 80% AM from 150 kHz...80 MHz
Voltage variation IEC 61000-4-29	10 ms interruption on DC supply ports
North American temp code	T4
UKEX/ATEX temp code	T4
IECEX temp code	T4
Enclosure type	None (open-style)

- (1) The additional supported mounting orientations are inverted horizontal, vertical, inverted vertical, upside down, and upside up.

## 5069-IB8S and 5069-IB8SK

### Safety Sinking Input Modules

Single Channel with Switches and Light Curtain Wiring

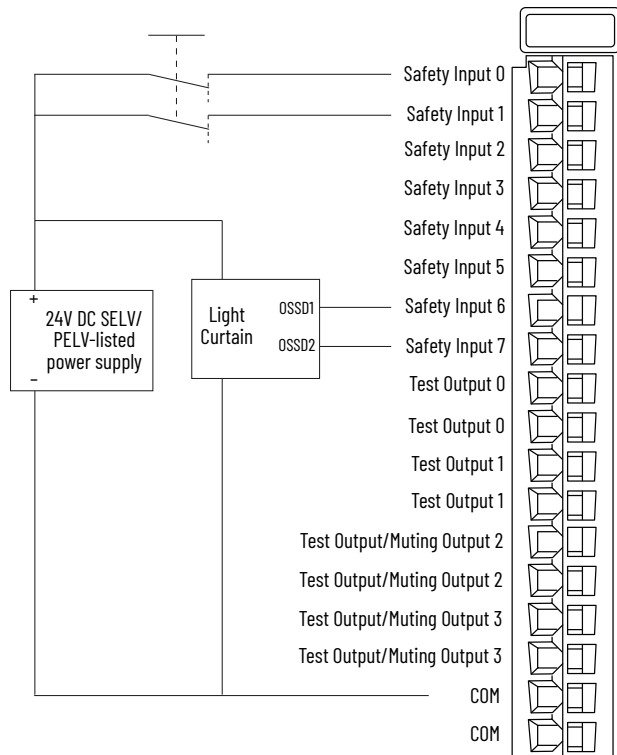

Single Channel with Switches and Muting Lamp Wiring

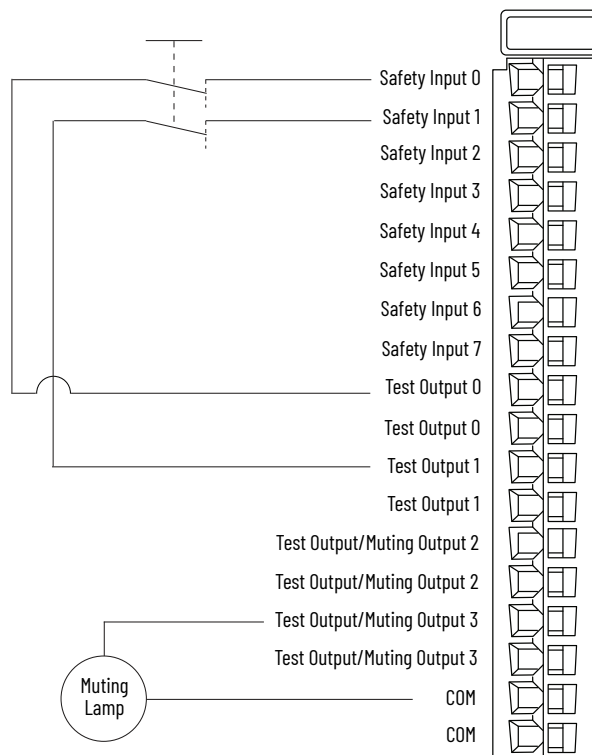

**IMPORTANT**

- When the module is wired as shown, it is suitable for applications that are rated up to, and including, **Category 3** as defined in ISO 13849-1.
- The switches are suitable for applications that are rated up to, and including, SIL CL 3, PLe, Cat. 3.
- The light curtain is suitable for applications that are rated up to, and including, SIL CL 3, PLe, Cat. 4.

<b>Channel Connections</b>	The diagram shows devices that are connected to safety input channels 0, 1, 6, and 7. You aren't restricted to using only those channels. You can connect devices to any safety input channel or combination of channels as needed.
<b>SA Power</b>	Connections to an external power supply that provides SA power are made via the SA power RTB on one of the following: <ul style="list-style-type: none"> <li>Compact GuardLogix 5380 controller</li> <li>5069-AENTR or 5069-AEN2TR EtherNet/IP Adapter</li> <li>5069-FPD field potential distributor</li> </ul>

**IMPORTANT**

- Remember the following:
- The 5069-IB8S and 5069-IB8SK modules use DC SA power. You must connect DC power to the component, that is, the controller, adapter, or field potential distributor that provides SA power to the modules.
  - If you install modules in a system that use AC SA power and DC SA power, you must install them on separate SA power buses.
  - You use a 5069-FPD field potential distributor to establish a new SA power bus in a system. SA power buses are isolated from each other. To keep the modules on separate SA power buses, complete these steps.
    - Install the modules that use one type of SA power, for example DC, to the right of the adapter or controller, that is, the first SA power bus.
    - Install the 5069-FPD field potential distributor to establish a second SA power bus.
    - Install the modules that use the other type of SA power, for example AC, on the second SA power bus.

**IMPORTANT**

- When the module is wired as shown, and the requirements listed are met in the project of the safety controller, it is suitable for applications that are rated up to, and including, **Category 4** as defined in ISO 13849-1. To achieve that suitability rating, you may have to perform diagnostic testing and monitoring of the safety function. One diagnostic test method is to configure the safety input channel for Safety Pulse Test to test the circuit for short circuits to 24V DC.
- Safety input pairs must be associated with different Test Output sources.
- When the power supply and muting lamp are configured for a test output, you must connect the return wire on the device to a COM point on the module.

<b>Channel Connections</b>	The diagram shows devices that are connected to safety input channels 0 and 1, and to test outputs 0 and 1. You aren't restricted to using only those safety input channels. You can connect devices to any safety input channel or combination of channels as needed.
<b>SA Power</b>	Connections to an external power supply that provides SA power are made via the SA power RTB on one of the following: <ul style="list-style-type: none"> <li>Compact GuardLogix 5380 controller</li> <li>5069-AENTR or 5069-AEN2TR EtherNet/IP Adapter</li> <li>5069-FPD field potential distributor</li> </ul>

**IMPORTANT**

- Remember the following:
- The 5069-IB8S and 5069-IB8SK modules use DC SA power. You must connect DC power to the component, that is, the controller, adapter, or field potential distributor that provides SA power to the modules.
  - If you install modules in a system that use AC SA power and DC SA power, you must install them on separate SA power buses.
  - You use a 5069-FPD field potential distributor to establish a new SA power bus in a system. SA power buses are isolated from each other. To keep the modules on separate SA power buses, complete these steps.
    - Install the modules that use one type of SA power, for example DC, to the right of the adapter or controller, that is, the first SA power bus.
    - Install the 5069-FPD field potential distributor to establish a second SA power bus.
    - Install the modules that use the other type of SA power, for example AC, on the second SA power bus.



**Single Channel with Sensor Wiring**

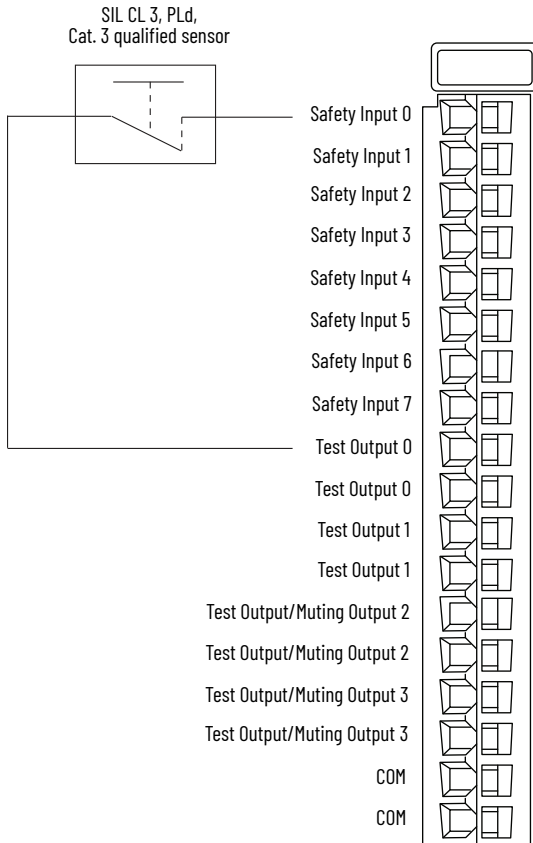

**IMPORTANT**

When the module is wired as shown, and the requirements listed are met in the project of the safety controller, it is suitable for applications that are rated up to, and including, Category 3 as defined in ISO 13849-1.

To achieve that suitability rating, you must meet the following requirements:

- Fault Exclusion is an External Wiring fault.
- Use a SIL CL 3, PLd, Cat. 3 qualified sensor.
- One of the following configuration combinations:  
 Input Point Mode = Safety Pulse Test  
 Test Output Mode = Pulse Test  
 Input Point Mode = Safety  
 Test Output Mode = Power Supply

<b>Channel Connections</b>	The diagram shows a device that is connected to safety input channel 0 and test output channel 0. You aren't restricted to using only those channels. You can connect devices to any safety input channel or combination of channels as needed. We recommend that you connect even-numbered input points to even-numbered test output points and odd-numbered input points to odd-numbered test output points. This wiring practice can maximize diagnostic independence and separation.
<b>SA Power</b>	Connections to an external power supply that provides SA power are made via the SA power RTB on one of the following: <ul style="list-style-type: none"> <li>• Compact GuardLogix 5380 controller</li> <li>• 5069-AENTR or 5069-AEN2TR EtherNet/IP Adapter</li> <li>• 5069-FPD field potential distributor</li> </ul>

**IMPORTANT**

Remember the following:

- The 5069-IB8S and 5069-IB8SK modules use DC SA power. You must connect DC power to the component, that is, the controller, adapter, or field potential distributor that provides SA power to the modules.
- If you install modules in a system that use AC SA power and DC SA power, you must install them on separate SA power buses.
- You use a 5069-FPD field potential distributor to establish a new SA power bus in a system. SA power buses are isolated from each other. To keep the modules on separate SA power buses, complete these steps.
  1. Install the modules that use one type of SA power, for example DC, to the right of the adapter or controller, that is, the first SA power bus.
  2. Install the 5069-FPD field potential distributor to establish a second SA power bus.
  3. Install the modules that use the other type of SA power, for example AC, on the second SA power bus.
- The SA power to adjacent SA power electrical isolation that the 5069-FPD field potential distributor provides has a rating of 240V AC (continuous) reinforced insulation type.

### Technical Specifications - 5069-IB8S and 5069-IB8SK

Attribute	5069-IB8S, 5069-IB8SK	
Inputs	8 channels, safety sinking	
Test Outputs	2 test output channels 2 test output/muting output channels	
Voltage category	12/24V DC source	
Voltage and current ratings	System mounted in horizontal orientation:	System mounted in any orientation other than horizontal (module derating) <sup>(1)</sup> :
Input Rating	2.5 mA per channel	2.5 mA per channel
Test Output Rating	300 mA per channel	200 mA per channel
MOD power	75 mA @ 18...32V DC	75 mA @ 18...32V DC
MOD power (passthrough) <sup>(2)</sup>	5 A @ 18...32V DC	5 A @ 18...32V DC
SA power	1.3 A @ 18...32V DC	100 mA @ 18...32V DC
SA power (passthrough) <sup>(2)</sup>	9.95 A @ 18...32V DC	5 A @ 18...32V DC
Do not exceed 5 A MOD or SA power (passthrough) current draw in any orientation other than Horizontal.		
Power dissipation, max	3.5 W	
Thermal dissipation, max	4 W	
Isolation voltage	250V (continuous), Basic Insulation Type	
Module keying	Electronic module keying, software configurable	
Indicators	1 green/red module status indicator 1 green/red SA power status indicator 12 yellow/red I/O status indicators	
Slot width	1	
Dimensions (HxWxD), approx	144.57 x 22 x 105.42 mm (5.69 x 0.87 x 4.15 in.)	
DIN rail	Compatible zinc-plated chromate-passivated steel DIN rail. You can use the EN50022 - 35 x 7.5 mm (1.38 x 0.30 in.) DIN rail.	
RTB	One of these RTB types. • 5069-RTB18-SPRING RTB • 5069-RTB18-SCREW RTB <b>IMPORTANT:</b> You must order RTBs separately. RTBs do not ship with Compact 5000 I/O modules. We recommend that you order only the RTB type that your system requires.	
RTB torque (5069-RTB18-SCREW RTB only)	0.4 N•m (3.5 lb•in)	
RTB keying	None	
Wire type	Copper	
Wire category <sup>(3)</sup>	2 - signal ports 1 wire per terminal for each signal port	
Wire size		
5069-RTB18-SCREW RTB	0.5...1.5 mm <sup>2</sup> (22...16 AWG) solid or stranded copper wire rated at 105 °C (221 °F), or greater, 3.5 mm (0.14 in.) max diameter including insulation	
5069-RTB18-SPRING RTB	0.5...1.5 mm <sup>2</sup> (22...16 AWG) solid or stranded copper wire rated at 105 °C (221 °F), or greater, 2.9 mm (0.11 in.) max diameter including insulation	
Insulation-stripping length		
5069-RTB18-SCREW RTB	12 mm (0.47 in.)	
5069-RTB18-SPRING RTB	10 mm (0.39 in.)	
Weight, approx	175 g (0.39 lb)	

### Technical Specifications - 5069-IB8S and 5069-IB8SK

Attribute	5069-IB8S, 5069-IB8SK
<b>Safety Inputs</b>	
On-state voltage, min	10V DC
On-state voltage, nom	24V DC
On-state voltage, max	32V DC
On-state current, min	1.8 mA
On-state current, nom	2 mA
On-state current, max	2.2 mA
Off-state voltage, max	5V DC
Off-state current, max	1.5 mA
Input delay time	
Off to On	Selectable time: 0 ms...50 ms Default is 0 ms
On to Off	Selectable time: 0 ms...50 ms Default is 0 ms
Safety integrity level (SIL)	SIL CL 3, PLc, Cat. 4
Safety reaction time (SRT)	6 ms
<b>Test Outputs</b>	
Output current per channel, max	0.3 A
Output current per group, max	1.2 A
Output current per module, max	1.2 A
Test output pulse width	< 700 µs
Test output pulse period	< 100 ms
Test output field capacitance, max	0.5 µF
Test output short circuit protection	Yes
Test output leakage current	1.5 mA
Test output overvoltage protection <sup>(4)</sup>	Yes
SA power reverse voltage protection	Yes
SA power overvoltage protection, max	36.5V DC
Time stamp of inputs	No
CIP Sync™	Yes
Overrides	No
Pulse latching	No
Events	No
Pattern matching	No
Extended counters	No
Scheduled outputs	No
Power consumption	3.8 W

- The additional supported mounting orientations are inverted horizontal, vertical, inverted vertical, upside down, and upside up.
- Level of Mod or SA power current that passes through the module depends on the system configuration, such as, module slot location and the other module types that are used in the system. For more information, see the controller user manuals in [Additional Resources on page 63](#).
- Use this Conductor Category information to plan conductor routes. For more information, see the Industrial Automation Wiring and Grounding Guidelines, publication [1770-4.1](#) and the appropriate system-level installation manual.
- Also known as Thermal Shutoff.

For **Certifications** and **Environmental Specifications**, see [page 39](#).

# 5069-OBV8S, 5069-OBV8SK

## Safety Output Modules

You can use the safety output modules in Bipolar mode or Sourcing mode.

**Bipolar Mode - Single Channel Output Wiring**

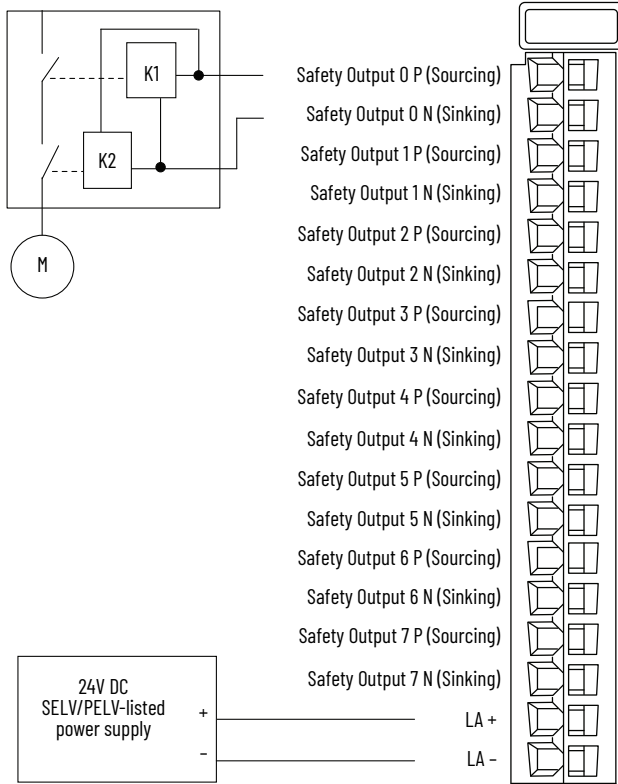

When the module is wired as shown, and the requirements listed are met in the project of the safety controller, it is suitable for applications that are rated up to, and including, **Category 4** as defined in ISO 13849-1.

To achieve that suitability rating, you may have to perform diagnostic testing and monitoring of the safety function. One diagnostic test method is to configure the safety output channel for Safety Pulse Test to test the circuit for short circuits to 24V DC. Configure the application so that a No Load fault can only be detected if the wires from both the P- terminal and the N- terminal are disconnected.

For Category 4 applications, if your application remains in safe state, that is, the output is off, for a prolonged duration, we recommend that you take one of the following actions:

- Apply output monitoring at the actuator. The monitoring can be direct or indirect.
- Limit the safe state to no more than 24 hours.
- Conduct functional test if safe state dwell time increases.

<b>Connection Pairs</b>	The terminals for each channel function as a Bipolar connection pair when you use a 5069-OBV8S or 5069-OBV8SK module in Bipolar switching mode. For example, the Safety Output 0 P (Sourcing) terminal and the Safety Output 0 N (Sinking) terminal are a Bipolar connection pair. That is, they are a P-N pair. When the module is in Bipolar switching mode, you must connect the device to both terminals.
<b>Channel Connections</b>	This wiring example shows connections to the P-N pair for Safety Output 0. You are not limited to using only channel 0 in this mode. You can use all channel pairs as determined by your application.
<b>LA Power</b>	The Local Actuator (LA+ and LA-) power connections are used to supply field-side power to the module.

**IMPORTANT**

Remember the following:

- The 5069-OBV8S and 5069-OBV8SK modules do not draw current from the SA power bus. Still, the modules are DC-type modules and you must install them on a DC SA power bus.
- If you install modules in a system that use AC SA power and DC SA power, you must install them on separate SA power buses.
- You use a 5069-FPD field potential distributor to establish a new SA power bus in a system. SA power buses are isolated from each other. To keep the modules on separate SA power buses, complete these steps.
  1. Install the modules that use one type of SA power, for example DC, to the right of the adapter or controller, that is, the first SA power bus.
  2. Install the 5069-FPD field potential distributor to establish a second SA power bus.
  3. Install the modules that use the other type of SA power, for example AC, on the second SA power bus.
- We strongly recommend that, if you have a direct connection between the safety output module and an input module and those modules are powered by separate power supplies that you connect SA- and LA- together. This practice helps to prevent diagnostics disruption due to grounding float.

**Bipolar Mode - Single Channel with Actuator Wiring**

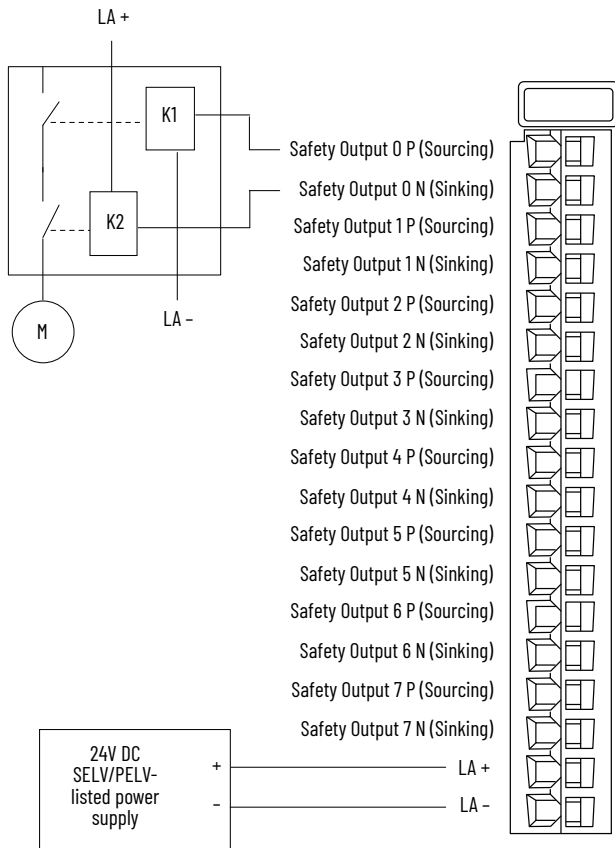

When the module is wired as shown, and the requirements listed are met in the project of the safety controller, it is suitable for applications that are rated up to, and including, **Category 4** as defined in ISO 13849-1.

To achieve that suitability rating, you may have to perform diagnostic testing and monitoring of the safety function. One diagnostic test method is to configure the safety output channel for Safety Pulse Test to test the circuit for short circuits to 24V DC.

- We strongly recommend that you connect separate shielded cables to the P terminal and the N terminal to reduce the possibility of a wire short between the terminals. If a wire-short fault is detected across the P-N pair, the module outputs are turned off, but the actuator that is connected to it remains on.
- Configure the application so that No Load and Overload conditions are only detectable at the P terminal.

For Category 4 applications, if your application remains in safe state, that is, the output is off, for a prolonged duration, we recommend that you take one of the following actions:

- Apply output monitoring at the actuator. The monitoring can be direct or indirect.
- Limit the safe state to no more than 24 hours.
- Conduct functional test if safe state dwell time increases.

<b>Actuator LA Power</b>	In this wiring configuration, you must connect the LA+ terminal to an SELV/PELV-listed power supply. The LA+ and LA- on the actuator must be connected to the same power supply as the LA+ and LA- on the module.
<b>Connection Pairs</b>	The terminals for each channel function as a Bipolar connection pair when you use a 5069-OBV8S or 5069-OB8VSK module in Bipolar switching mode. For example, the Safety Output 0 P (Sourcing) terminal and the Safety Output 0 N (Sinking) terminal are a Bipolar connection pair. That is, they are a P-N pair. When the module is in Bipolar switching mode, you must connect the device to both terminals.
<b>Channel Connections</b>	This wiring example shows connections to the P-N pair for Safety Output 0. You are not limited to using only channel 0 in this mode. You can use all channel pairs as determined by your application.
<b>LA Power</b>	The Local Actuator (LA+ and LA-) power connections are used to supply field-side power to the module.

**IMPORTANT**

Remember the following:

- The 5069-OBV8S and 5069-OBV8SK modules do not draw current from the SA power bus. Still, the modules are DC-type modules and you must install them on a DC SA power bus.
- If you install modules in a system that use AC SA power and DC SA power, you must install them on separate SA power buses.
- You use a 5069-FPD field potential distributor to establish a new SA power bus in a system. SA power buses are isolated from each other. To keep the modules on separate SA power buses, complete these steps.
  1. Install the modules that use one type of SA power, for example DC, to the right of the adapter or controller, that is, the first SA power bus.
  2. Install the 5069-FPD field potential distributor to establish a second SA power bus.
  3. Install the modules that use the other type of SA power, for example AC, on the second SA power bus.
- We strongly recommend that, if you have a direct connection between the safety output module and an input module and those modules are powered by separate power supplies that you connect SA- and LA- together. This practice helps to prevent diagnostics disruption due to grounding float.

**Bipolar Mode - Single Channel with Actuator Subsystem Wiring**

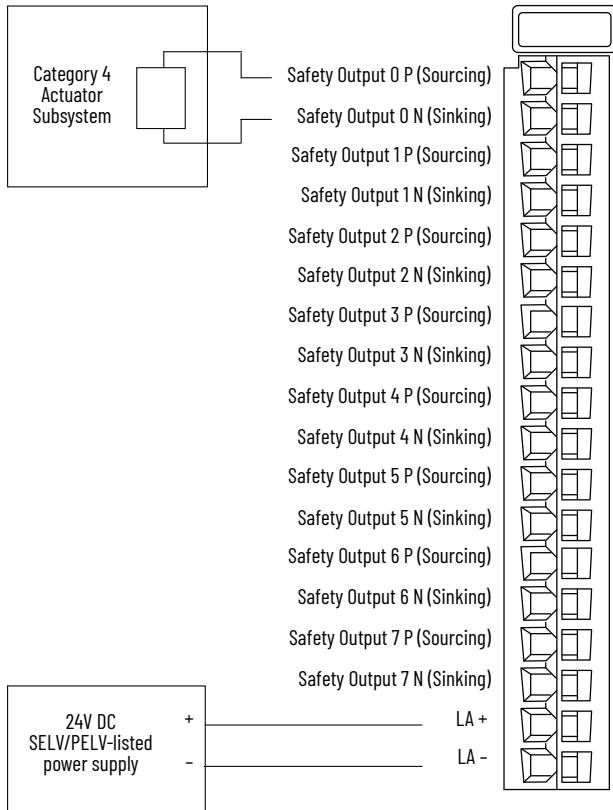

When the module is wired as shown, and the requirements listed are met in the project of the safety controller, it is suitable for applications that are rated up to, and including, **Category 4** as defined in ISO 13849-1. To achieve that suitability rating, you may have to perform diagnostic testing and monitoring of the safety function. One diagnostic test method is to configure the safety output channel for Safety Pulse Test to test the circuit for short circuits to 24V DC. For Category 4 applications, if your application remains in safe state, that is, the output is off, for a prolonged duration, we recommend that you take one of the following actions:

- Apply output monitoring at the actuator. The monitoring can be direct or indirect.
- Limit the safe state to no more than 24 hours.
- Conduct functional test if safe state dwell time increases.
- A qualified actuator must be installed, for example, in accordance with IEC 60947.

<b>Connection Pairs</b>	The terminals for each channel function as a Bipolar connection pair when you use a 5069-OBV8S or 5069-OBV8SK module in Bipolar switching mode. For example, the Safety Output 0 P (Sourcing) terminal and the Safety Output 0 N (Sinking) terminal are a Bipolar connection pair. That is, they are a P-N pair. When the module is in Bipolar switching mode, you must connect the device to both terminals.
<b>Channel Connections</b>	This wiring example shows connections to the P-N pair for Safety Output 0. You aren't limited to using channel 0 in this mode. You can use all channel pairs as determined by your application.
<b>LA Power</b>	The Local Actuator (LA+ and LA-) power connections are used to supply field-side power to the module.

**IMPORTANT**  
Remember the following:

- The 5069-OBV8S and 5069-OBV8SK modules do not draw current from the SA power bus. Still, the modules are DC-type modules and you must install them on a DC SA power bus.
- If you install modules in a system that use AC SA power and DC SA power, you must install them on separate SA power buses.
- You use a 5069-FPD field potential distributor to establish a new SA power bus in a system. SA power buses are isolated from each other. To keep the modules on separate SA power buses, complete these steps.
  1. Install the modules that use one type of SA power, for example DC, to the right of the adapter or controller, that is, the first SA power bus.
  2. Install the 5069-FPD field potential distributor to establish a second SA power bus.
  3. Install the modules that use the other type of SA power, for example AC, on the second SA power bus.
- We strongly recommend that, if you have a direct connection between the safety output module and an input module and those modules are powered by separate power supplies that you connect SA- and LA- together. This practice helps to prevent diagnostics disruption due to grounding float.
- The SA power to adjacent SA power electrical isolation that the 5069-FPD field potential distributor provides has a rating of 240V AC (continuous) reinforced insulation type.

Sourcing Mode - Single Channel with Actuator Wiring

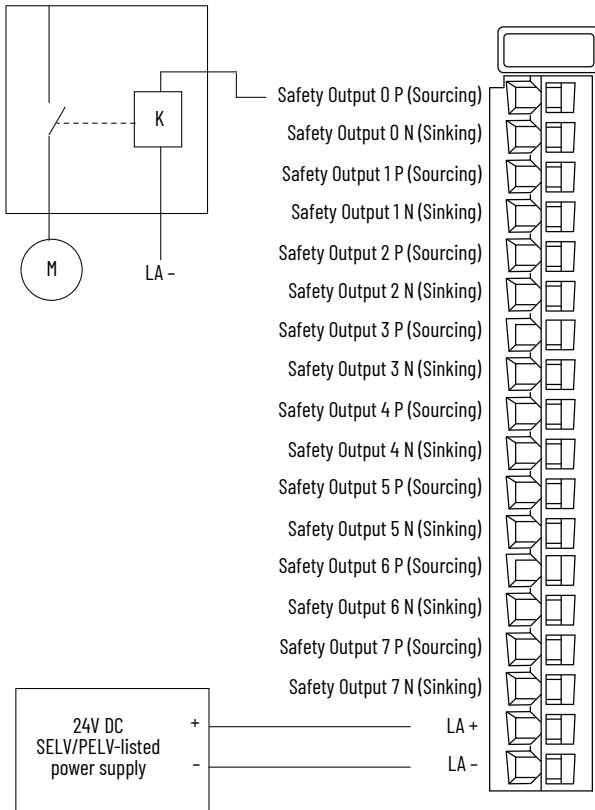

Sourcing Mode - Dual Channel with Actuator Wiring

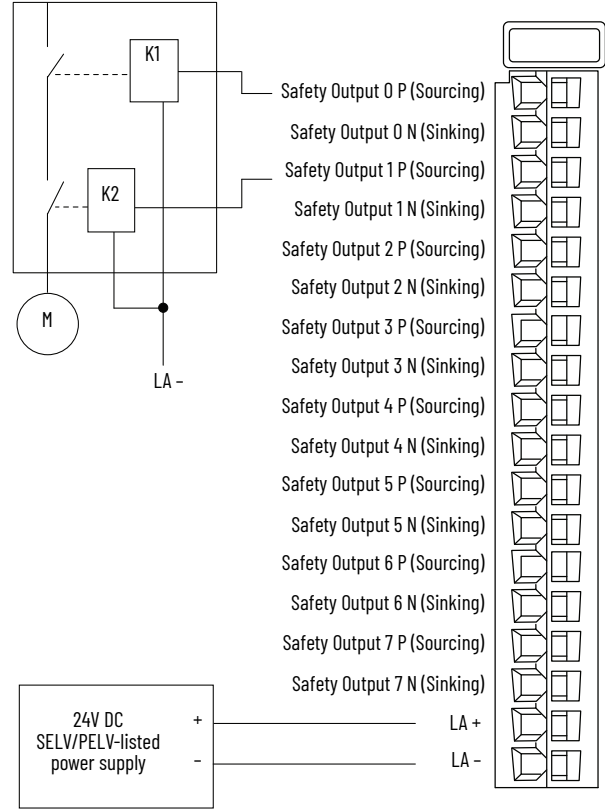

When the module is wired as shown, it is suitable for applications that are rated up to, and including, **Category 2** as defined in ISO 13849-1. To achieve that suitability rating, you may have to perform diagnostic testing and monitoring of the safety function. One diagnostic test method is to configure the safety output channel for Safety Pulse Test to test the circuit for short circuits to 24V DC.

<b>Channel Connections</b>	This wiring example shows connection to Safety Output 0. You aren't limited to using channel 0 in this mode. You can use all channels as determined by your application.
<b>LA Power</b>	The Local Actuator (LA+ and LA-) power connections are used to supply field-side power to the module.

**IMPORTANT**

- Remember the following:
- The 5069-OBV8S and 5069-OBV8SK modules do not draw current from the SA power bus. Still, the modules are DC type modules, and you must install them on a DC SA power bus.
  - If you install modules in a system that use AC SA power and DC SA power, you must install them on separate SA power buses.
  - You use a 5069-FPD field potential distributor to establish a new SA power bus in a system. SA power buses are isolated from each other. To keep the modules on separate SA power buses, complete these steps.
    - Install the modules that use one type of SA power, for example DC, to the right of the adapter or controller, that is, the first SA power bus.
    - Install the 5069-FPD field potential distributor to establish a second SA power bus.
    - Install the modules that use the other type of SA power, for example AC, on the second SA power bus.
  - We strongly recommend that, if you have a direct connection between the safety output module and an input module and those modules are powered by separate power supplies that you connect SA- and LA- together. This practice helps to prevent diagnostics disruption due to grounding float.

When the module is wired as shown, it is suitable for applications that are rated up to, and including, **Category 4** as defined in ISO 13849-1. To achieve that suitability rating, you may have to perform diagnostic testing and monitoring of the safety function. One diagnostic test method is to configure the safety output channel for Safety Pulse Test to test the circuit for short circuits to 24V DC.

- For Category 4 applications, if your application remains in safe state, that is, the output is off, for a prolonged duration, we recommend that you take one of these actions:
- Apply output monitoring at the actuator. The monitoring can be direct or indirect.
  - Limit the safe state to no more than 24 hours.
  - Conduct functional test if safe state dwell time increases.

<b>Connection Pairs</b>	When you use dual-channel sourcing wiring on the 5069-OBV8S or 5069-OBV8SK module, you must connect the devices to dual-channel connection pairs. For example, the devices are connected to channels 4 and 5 because they are a connection pair. The following channels are dual-channel connection pairs: <ul style="list-style-type: none"> <li>Channels 0 and 1 (shown)</li> <li>Channels 2 and 3</li> <li>Channels 4 and 5</li> <li>Channels 6 and 7</li> </ul>
<b>Channel Connections</b>	This wiring example shows connections to Safety Output 0 P and Safety Output 1 P. You aren't limited to using channels 0 and 1 in this mode. You can use all channel pairs as determined by your application.
<b>LA Power</b>	The Local Actuator (LA+ and LA-) power connections are used to supply field-side power to the module.

**IMPORTANT**

- Remember the following:
- The 5069-OBV8S and 5069-OBV8SK modules do not draw current from the SA power bus. Still, the modules are DC-type modules and you must install them on a DC SA power bus.
  - If you install modules in a system that use AC SA power and DC SA power, you must install them on separate SA power buses.
  - You use a 5069-FPD field potential distributor to establish a new SA power bus in a system. SA power buses are isolated from each other. To keep the modules on separate SA power buses, complete these steps.
    - Install the modules that use one type of SA power, for example DC, to the right of the adapter or controller, that is, the first SA power bus.
    - Install the 5069-FPD field potential distributor to establish a second SA power bus.
    - Install the modules that use the other type of SA power, for example AC, on the second SA power bus.
  - We strongly recommend that, if you have a direct connection between the safety output module and an input module and those modules are powered by separate power supplies that you connect SA- and LA- together. This practice helps to prevent diagnostics disruption due to grounding float.

Sourcing Mode - Single Channel with Actuator Subsystem Wiring

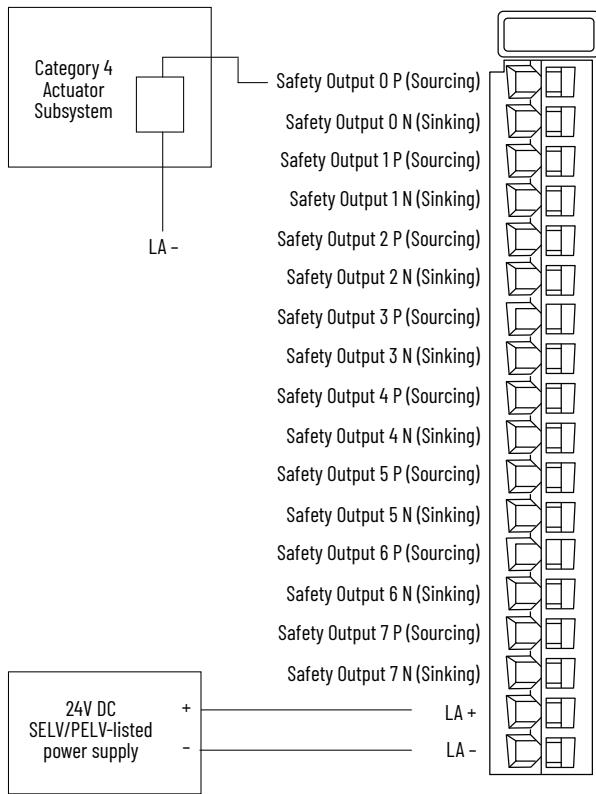

When the module is wired as shown, and the requirements listed are met in the project of the safety controller, it is suitable for applications that are rated up to, and including, **Category 4** as defined in ISO 13849-1.

To achieve that suitability rating, you may have to perform diagnostic testing and monitoring of the safety function. One diagnostic test method is to configure the safety output channel for Safety Pulse Test to test the circuit for short circuits to 24V DC.

- All power source cables must be installed separately, for example, with a separate cable duct or shielded cable. Power source cables are connections to the MOD+, SA+, or LA+ terminals.
  - Otherwise, a Short Circuit condition between SA+ and P can be detected and the output is turned off but the actuator that is connected to it remains on.
  - You must connect two ground terminals. Otherwise, the maximum residual current at signal 0 cannot be maintained if only one ground line is connected and it is interrupted.
  - A qualified actuator must be installed, for example, in accordance with IEC 60947.
- For Category 4 applications, if your application remains in safe state, that is, the output is off, for a prolonged duration, we recommend that you take one of the following actions:
- Apply output monitoring at the actuator. The monitoring can be direct or indirect.
  - Limit the safe state to no more than 24 hours.
  - Conduct functional test if safe state dwell time increases.

<b>Channel Connections</b>	This wiring example shows connections to Safety Output 0. You aren't limited to using channel 0 in this mode. You can use all channels as determined by your application.
<b>LA Power</b>	The Local Actuator (LA+ and LA -) power connections are used to supply field-side power to the module.

**IMPORTANT**

Remember the following:

- The 5069-OBV8S and 5069-OBV8SK modules do not draw current from the SA power bus. Still, the modules are DC-type modules and you must install them on a DC SA power bus.
- If you install modules in a system that use AC SA power and DC SA power, you must install them on separate SA power buses.
- You use a 5069-FPD field potential distributor to establish a new SA power bus in a system. SA power buses are isolated from each other. To keep the modules on separate SA power buses, complete these steps.
  1. Install the modules that use one type of SA power, for example DC, to the right of the adapter or controller, that is, the first SA power bus.
  2. Install the 5069-FPD field potential distributor to establish a second SA power bus.
  3. Install the modules that use the other type of SA power, for example AC, on the second SA power bus.
- We strongly recommend that, if you have a direct connection between the safety output module and an input module and those modules are powered by separate power supplies that you connect SA- and LA- together. This practice helps to prevent diagnostics disruption due to grounding float.

Technical Specifications - 5069-OBV8S, 5069-OBV8SK

Attribute	5069-OBV8S, 5069-OBV8SK	
Outputs	8	
Voltage category	24V DC	
Voltage and current ratings	System mounted in horizontal orientation:	System mounted in any orientation other than horizontal (module derating) <sup>(1)</sup> :
Output Rating	1 A per channel	0.7 A per channel
MOD power	75 mA @ 18...32V DC	75 mA @ 18...32V DC
MOD power (passthrough) <sup>(2)</sup>	5 A @ 18...32V DC	5 A @ 18...32V DC
LA power	1 A per channel @ 18...32V DC 8 A per module @ 18...32V DC	0.7 A per channel @ 18...32V DC 5.6 A per module @ 18...32V DC
SA power (passthrough) <sup>(2)</sup> The module does not draw SA power current.	9.95 A @ 18...32V DC	5 A @ 18...32V DC
Horizontal orientation - Do not exceed 5 A Mod or power (passthrough) current draw. Do not exceed 10 A SA power (passthrough) current draw. Any orientation other than Horizontal - Do not exceed 5 A MOD or SA power (passthrough) current draw.		
Power dissipation, max	6.5 W	
Thermal dissipation, max	6.5 W	
Isolation voltage	250V (continuous), Basic Insulation Type No isolation between LA power and output ports No isolation between individual output ports	
Module keying	Electronic keying via programming software	
Indicators	1 green/red module status indicator 1 green/red SA power status indicator 16 yellow/red I/O status indicators	
Slot width	1.5	
Dimensions (HxWxD), approx	144.57 x 36 x 105.42 mm (5.69 x 1.42 x 4.15 in.)	
DIN rail	Compatible zinc-plated chromate-passivated steel DIN rail. You can use the EN50022 - 35 x 7.5 mm (1.38 x 0.30 in.) DIN rail.	
RTB	One of these RTB types. • 5069-RTB18-SPRING RTB • 5069-RTB18-SCREW RTB <b>IMPORTANT:</b> You must order RTBs separately. RTBs do not ship with Compact 5000 I/O modules. We recommend that you order only the RTB type that your system requires.	
RTB torque (5069-RTB18-SCREW RTB only)	0.4 N-m (3.5 lb-in)	
RTB keying	None	
Wire type	Copper	
Wire category <sup>(3)</sup>	2 - signal ports 1 wire per terminal for each signal port	
Wire size	5069-RTB18-SCREW RTB: 0.5...1.5 mm <sup>2</sup> (22...16 AWG) solid or stranded copper wire rated at 105 °C (221 °F), or greater, 3.5 mm (9/64 in.) insulated max diameter 5069-RTB18-SPRING RTB: 0.5...1.5 mm <sup>2</sup> (22...16 AWG) solid or stranded copper wire rated at 105 °C (221 °F), or greater, 2.9 mm (1/8 in.) insulated max diameter	
Insulation-stripping length	5069-RTB18-SCREW RTB: 12 mm (0.47 in.) 5069-RTB18-SPRING RTB: 10 mm (0.39 in.)	
Weight, approx	240 g (0.53 lb.)	
LA power attributes		
On-state voltage, min	17.5V DC	
On-state voltage, nom	24V DC	
On-state voltage, max	32V DC	
On-state voltage drop, max	0.5V DC	
On-state current per channel, min	10 mA	
Off-state voltage, max	0.5V DC	

## Technical Specifications - 5069-0BV8S, 5069-0BV8SK

Attribute	5069-0BV8S, 5069-0BV8SK
Off-state leakage current per point, max <sup>(4)</sup>	1.5 mA
Output current rating per channel	1 A
Surge current per point, max	1.5 A
Output delay time (backplane to screw)	
Off to On	4 ms, max
On to Off	4 ms, max
Safety Integrity Level	SIL CL 3, PLe, Cat. 4
Safety reaction time (SRT)	4.5 ms
Pulse width, min	400 µs
Field power loss detection, per point	Yes
No load detection diagnostics, per point	Yes
Output short circuit/overload detection, per point	Yes
Output short circuit/overload protection, per point	Yes
Output overtemperature detection, per point	Yes
Output overtemperature protection, per point	Yes
Reverse voltage protection	Yes
Overvoltage protection, max	Yes
CIP Sync™	Yes
Output control in fault mode per point	No
Output states in program mode per point	Off
Output states in fault mode per point	Off
Duration of fault mode per point	Forever - Safety outputs turn off when the fault is detected and remain off until the cause of the fault is removed and the safety outputs are commanded into the safe state.

- (1) The additional supported mounting orientations are inverted horizontal, vertical, inverted vertical, upside down, and upside up.
- (2) Level of Mod or SA power current that passes through the module depends on the system configuration, such as, module slot location and the other module types that are used in the system. For more information, see the controller user manuals in [Additional Resources on page 63](#).
- (3) Use this Conductor Category information to plan conductor routes. See the Industrial Automation Wiring and Grounding Guidelines, publication [1770-4.1](#).
- (4) Recommended Loading Resistor - To limit the effects of leakage current through solid-state outputs, you can connect a loading resistor in parallel with your load. For 24V DC operation, use a 5.6 KΩ, 0.5 W resistor for transistor operation.

For **Certifications** and **Environmental Specifications**, see [page 39](#).



## Specialty Modules

The following specialty modules are available.

Cat. No.	Description	Page
5069-AENTR and 5069-AENTRK	EtherNet/IP adapters	51
5069-AEN2TR	EtherNet/IP adapter	52
5069-ARM	Address reserve module	54
5069-FPD	Field potential distributor	54
5069-HSC2XOB4	High speed counter module	56
5069-SERIAL	Serial module	60

### Certifications - Specialty Modules

Certification <sup>(1)</sup>	5069-ARM	5069-FPD	5069-HSC2XOB4	5069-AENTR, 5069-AENTRK <sup>(2)</sup>	5069-SERIAL
c-UL-us	UL Listed Industrial Control Equipment, certified for US and Canada. See UL File E65584. UL Listed for Class I, Division 2 Group A,B,C,D Hazardous Locations, certified for U.S. and Canada. See UL File E194810.			UL Listed Industrial Control Equipment, certified for US and Canada. See UL File E322657. UL Listed for Class I, Division 2 Group A,B,C,D Hazardous Locations, certified for U.S. and Canada. See UL File E334470.	
UKCA and CE	UK Statutory Instrument 2016 No. 1091 and European Union 2014/30/EU EMC Directive, compliant with: EN 61326-1; Meas./Control/Lab., Industrial Requirements EN 61000-6-2; Industrial Immunity EN 61000-6-4; Industrial Emissions EN 61131-2; Programmable Controllers (Clause 8, Zone A & B)			UK Statutory Instrument 2012 No. 3032 and European Union 2011/65/EU RoHS, compliant with: EN IEC 63000; Technical documentation	
	—			UK Statutory Instrument 2016 No. 1101 and European Union 2014/35/EU LVD, compliant with: EN 61010-2-201; Control Equipment Safety Requirements	
RCM	Australian Radiocommunications Act, compliant with: EN 61000-6-4; Industrial Emissions				
Ex	UK Statutory Instrument 2016 No. 1107 and European Union 2014/34/EU ATEX Directive, compliant with: EN IEC 60079-0; General Requirements EN IEC 60079-7; Explosive Atmospheres, Protection "e" II 3 G Ex ec IIC T4 Gc				
	DEMKO 15 ATEX 1455X and UL22UKEX2307X		DEMKO 16 ATEX 1758X and UL22UKEX2494X		DEMKO 15 ATEX 1484X and UL22UKEX2379
IECEX	When used at or below 125V AC				
	IECEX System, compliant with: EN IEC 60079-0; General Requirements EN IEC 60079-7; Explosive Atmospheres, Protection "e" II 3 G Ex ec IIC T4 Gc				
	IECEX UL 15.0007X		IECEX UL 15.0055X		IECEX UL 16.0124X
KC	When used at or below 125V AC				
	Korean Registration of Broadcasting and Communications Equipment, compliant with: Article 58-2 of Radio Waves Act, Clause 3				
Morocco	Arrêté ministériel n° 6404-15 du 1 er muharram 1437 Arrêté ministériel n° 6404-15 du 29 ramadan 1436				
CCC	CNCA-C23-01:2019 强制性产品认证实施规则 防爆电气 CNCA-C23-01:2019 CCC Implementation Rule Explosion-Proof Electrical Products				
	CCC: 202012230911301 and 2021122309113957				CCC: 2020312309000308
EtherNet/IP	—			ODVA conformance tested to EtherNet/IP specifications	—

(1) When marked. See the Product Certification link at [rok.auto/certifications](http://rok.auto/certifications) for Declarations of Conformity, Certificates, and other certification details.

(2) For 5069-AEN2TR module certifications, see [page 53](#).

## Environmental Specifications - Specialty Modules

Attribute	5069-ARM	5069-AENTR, 5069-AENTRK <sup>(1)</sup>	5069-FPD	5069-HSC2X0B4	5069-SERIAL
Temperature, operating IEC 60068-2-1 (Test Ad, Operating Cold) IEC 60068-2-2 (Test Bd, Operating Dry Heat) IEC 60068-2-14 (Test Nb, Operating Thermal Shock)	0...60 °C (32...140 °F)				
Temperature, surrounding air, max	60 °C (140 °F)				
Temperature, nonoperating IEC 60068-2-1 (Test Ab, Unpackaged Nonoperating Cold) IEC 60068-2-2 (Test Bb, Unpackaged Nonoperating Dry Heat) IEC 60068-2-14 (Test Na, Unpackaged Nonoperating Thermal Shock)	-40...+85 °C (-40...+185 °F)				
Relative humidity IEC 60068-2-30 (Test Db, Unpackaged Damp Heat)	5...95% noncondensing				
Vibration IEC 60068-2-6 (Test Fc, Operating)	5 g @ 10...500 Hz				
Shock, operating IEC 60068-2-27 (Test Ea, Unpackaged Shock)	30 g				
Shock, nonoperating IEC 60068-2-27 (Test Ea, Unpackaged Shock)	50 g				
Emissions	IEC 61000-6-4				
ESD immunity IEC 61000-4-2	6 kV contact discharges 8 kV air discharges				
Radiated RF immunity IEC 61000-4-3	10V/m with 1 kHz sine wave 80% AM from 80...6000 MHz				
EFT/B immunity IEC 61000-4-4	—	±3 kV @ 5 kHz on power ports ±3 kV @ 5 kHz on Ethernet ports	±4 kV @ 5 kHz on power ports	±4 kV @ 5 kHz on power ports ±2 kV @ 5 kHz on shielded output ports ±2 kV @ 5 kHz on shielded counter ports	±4 kV @ 5 kHz on power ports ±3 kV @ 5 kHz on communication ports
Surge transient immunity IEC 61000-4-5	—	±1 kV line-line (DM) and ±2 kV line-earth (CM) on power ports ±2 kV line-earth (CM) on Ethernet ports	±1 kV line-line (DM) and ±2 kV line-earth (CM) on power ports	±1 kV line-line (DM) and ±2 kV line-earth (CM) on power ports ±2 kV line-earth (CM) on shielded output ports ±2 kV line-earth (CM) on shielded counter ports	±1 kV line-line (DM) and ±2 kV line-earth (CM) on power ports ±2 kV line-earth (CM) on communication ports
Conducted RF immunity IEC 61000-4-6	—	10V rms with 1 kHz sine wave 80% AM from 150 kHz...80 MHz			
Voltage variation IEC 61000-4-29	—	On power and Ethernet ports	—		
ESD immunity IEC 61000-4-2	10 ms interruption on DC supply ports	—		10 ms interruption on MOD power port	—
North American temp code	T4				
UKEX/ATEX temp code	T4				
IECEX temp code	T4				
Enclosure type	None (open-style)				

(1) For 5069-AEN2TR module environmental specifications, see [page 53](#).

# 5069-AENTR and 5069-AENTRK

## EtherNet/IP Adapters

MOD Power (DC) Wiring

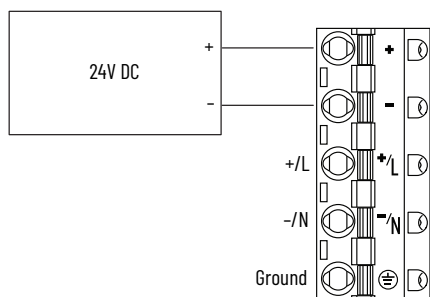

SA Power (DC) Wiring

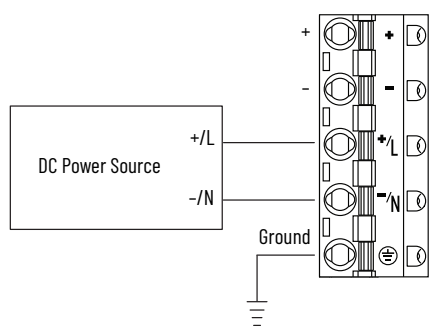

SA Power (AC) Wiring

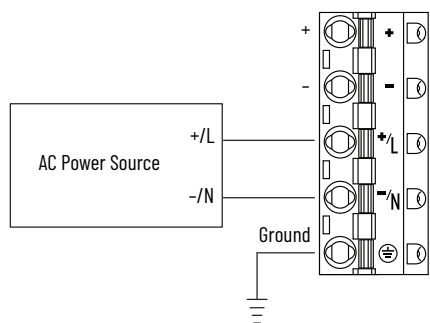

### Technical Specifications - 5069-AENTR and 5069-AENTRK

Attribute	5069-AENTR, 5069-AENTRK
Voltage and current ratings	
MOD power	220 mA @ 18...32V DC
MOD power inrush	1750 mA for 70 ms
MOD power (passthrough) <sup>(1)</sup>	9.78 A @ 18...32V DC
SA power	5 mA @ 0...32V DC 2 mA @ 0...240V AC, 47...63 Hz Ex, 125V AC Max
SA power (passthrough) <sup>(1)</sup>	9.95 A @ 0...32V DC 9.975 A @ 0...240V AC, 47...63 Hz Ex, 125V AC Max
Do not exceed 10 A current draw at the MOD or SA power RTB.	
Recommended external overcurrent protection	MOD power: 10...12A @ 22.5...43.2 A2t, Fast Acting SA power: 20 A @ 250V AC

### Technical Specifications - 5069-AENTR and 5069-AENTRK

Attribute	5069-AENTR, 5069-AENTRK
Power dissipation, max	8.5 W
Thermal dissipation, max	29 BTU/hr
Isolation voltage	300V (continuous), Basic Insulation Type, SA, and MOD power to Backplane 300V (continuous), Basic Insulation Type, SA to MOD power 300V (continuous), Basic Insulation Type, Ethernet to Backplane Type tested at 1500V AC for 60 s 300V (continuous), Double Insulation Type, Ethernet to MOD power 300V (continuous), Double Insulation Type, Ethernet to SA power Type tested at 4242V DC for 60 s No isolation between Ethernet ports
Module keying	Electronic keying via programming software
Dimensions (HxWxD), approx	138 x 56 x 105 mm (5.43 x 2.20 x 4.15 in.)
RTB	We recommend that you order only the RTB type that your system requires. RTBs are available in separately ordered 5069 RTB kits. The following kits are available: <ul style="list-style-type: none"> <li>Kit catalog number 5069-RTB5-SCREW kit contains two 5069-RTB5-SCREW RTBs.</li> <li>Kit catalog number 5069-RTB5-SPRING kit contains two 5069-RTB5-SPRING RTBs.</li> </ul> <b>IMPORTANT:</b> You must order RTBs separately. RTBs do not ship with Compact 5000 I/O EtherNet/IP adapters. We recommend that you order only the RTB type that your system requires.
RTB torque (5069-RTB5-SCREW RTB only)	0.5...0.6 N•m (4.4...5.3 lb•in)
RTB keying	None
Wiring category <sup>(2)(3)</sup>	2 - on signal ports 1 - on power ports 2 - on Ethernet ports
Wire size	0.25...2.5 mm <sup>2</sup> (22...14 AWG) solid or stranded copper wire rated at 105 °C (221 °F), or greater, 1.2 mm (3/64 in) insulation m, single wire connection only. Grounding: 2.5 mm <sup>2</sup> (14 AWG) solid or stranded copper wire rated at 105 °C (221 °F), or greater, 3.5 mm (0.14 in) max diameter including insulation, single wire connection only. Ethernet connections: Ethernet Cabling and Installation according to IEC 61918 and IEC 61784-5-2.
Insulation-stripping length	
5069-RTB5-SPRING RTB	10 mm (0.39 in.)
5069-RTB5-SCREW RTB	10 mm (0.39 in.)

- (1) Maximum level of Mod or SA power current that the adapter can pass through to the next module in the system.
- (2) Use this Conductor Category information to plan conductor routes. See the Industrial Automation Wiring and Grounding Guidelines, publication [1770-4.1](#).
- (3) Use this Conductor Category information to plan conductor routes as described in the appropriate System Level Installation Manual.

For **Certifications**, see [page 49](#).  
For **Environmental Specifications**, see [page 50](#).

# 5069-AEN2TR

## EtherNet/IP Adapter

MOD Power (DC) Wiring

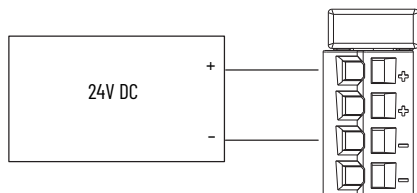

SA Power (DC) Wiring

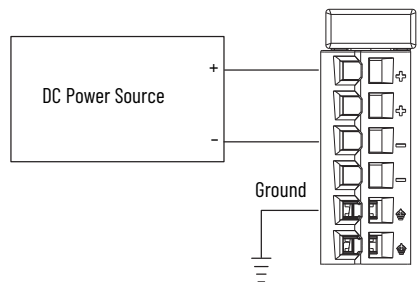

SA Power (AC) Wiring

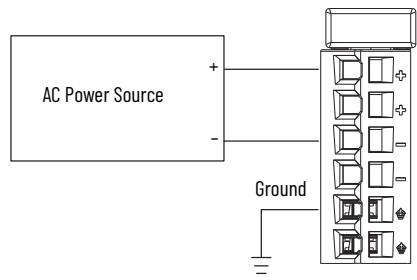

### Technical Specifications - 5069-AEN2TR

Attribute	5069-AEN2TR
Voltage and current ratings	
MOD power	450 mA @ 18...32V DC
MOD power inrush	850 mA for 125 ms
MOD power (passthrough) <sup>(1)</sup>	9.55 A @ 18...32V DC
SA power	10 mA @ 0...32V DC 25 mA @ 0...240V AC, 47...63 Hz ATEX/IECEX, 125V AC Max
SA power (passthrough) <sup>(1)</sup>	9.95 A @ 0...32V DC 9.975 A @ 0...240V AC, 47...63 Hz ATEX/IECEX, 125V AC Max
Do not exceed 10 A current draw at the MOD or SA power RTB.	
Recommended external overcurrent protection	-

### Technical Specifications - 5069-AEN2TR

Attribute	5069-AEN2TR
Power dissipation, max	8.5 W
Thermal dissipation, max	29 BTU/hr
Isolation voltage	250V (continuous), basic insulation type, SA and MOD power to backplane 250V (continuous), basic insulation type, SA to MOD power 250V (continuous), basic insulation type, Ethernet to backplane 250V (continuous), double insulation type, Ethernet to MOD power 250V (continuous), double insulation type, Ethernet to SA power 50V (continuous), functional insulation type, Ethernet to USB 250V (continuous), basic insulation type, USB to backplane 250V (continuous), double insulation type, USB to MOD power 250V (continuous), double insulation type, USB to SA power No isolation between Ethernet ports Type tested at 1500V AC for 60 s
Module keying	Electronic keying via programming software
Dimensions (HxWxD), approx	138 x 98 x 137 mm (5.43 x 3.86 x 5.39 in.)
RTB	RTBs are available in separately ordered 5069 RTB kits. The MOD power connection uses a 4-point RTB, and the SA power connection uses a 6-point RTBs. The following kits are available: <ul style="list-style-type: none"> <li>Kit catalog number 5069-RTB64-SCREW contains RTB catalog numbers 5069-RTB6-SCREW and 5069-RTB4-SCREW</li> <li>Kit catalog number 5069-RTB64-SPRING contains RTB catalog numbers 5069-RTB6-SPRING and 5069-RTB4-SPRING</li> </ul> <b>IMPORTANT:</b> You must order RTBs separately. RTBs do not ship with Compact 5000 I/O EtherNet/IP adapters. We recommend that you order only the RTB type that your system requires.
RTB torque (Screw RTBs only)	0.4 N•m (3.5 lb•in)
RTB keying	None
Wiring category <sup>(2)</sup>	3 - on USB port 2 - on power ports 2 - on Ethernet ports
Wire size	
5069-RTB4-SPRING, 5069-RTB6-SPRING RTBs	0.5...1.5 mm <sup>2</sup> (22...16 AWG) solid or stranded copper wire rated at 105 °C (221 °F), or greater, 2.9 mm (0.11 in.) max diameter including insulation, single wire connection only
5069-RTB4-SCREW, 5069-RTB6-SCREW RTBs	0.5...1.5 mm <sup>2</sup> (22...16 AWG) solid or stranded copper wire rated at 105 °C (221 °F), or greater, 3.5 mm (0.14 in.) max diameter including insulation, single wire connection only
Ethernet connections	Ethernet cabling and installation according to IEC 61918 and IEC 61784-5-2
Insulation-stripping length	
5069-RTB4-SPRING, 5069-RTB6-SPRING RTBs	10 mm (0.39 in.)
5069-RTB4-SCREW, 5069-RTB6-SCREW RTBs	12 mm (0.47 in.)

- (1) Maximum level of Mod or SA power current that the adapter can pass through to the next module in the system.
- (2) Use this Conductor Category information to plan conductor routes. See the Industrial Automation Wiring and Grounding Guidelines, publication [1770-4.1](#).

## Environmental Specifications - 5069-AEN2TR

Attribute	5069-AEN2TR
Temperature, operating IEC 60068-2-1 (Test Ab, Operating Cold), IEC 60068-2-2 (Test Bb, Unpackaged Nonoperating Dry Heat), IEC 60068-2-14 (Test Na, Operating Thermal Shock)	0...60 °C (32...140 °F)
Temperature, surrounding air, max	60 °C (140 °F)
Temperature, nonoperating IEC 60068-2-1 (Test Ab, Unpackaged Nonoperating Cold), IEC 60068-2-2 (Test Bb, Unpackaged Nonoperating Dry Heat), IEC 60068-2-14 (Test Na, Unpackaged Nonoperating Thermal Shock)	-40...+85 °C (-40...+185 °F)
Relative humidity IEC 60068-2-30 (Test Db, Unpackaged Damp Heat)	5...95% noncondensing
Vibration IEC 60068-2-6 (Test Fc, Operating)	5 g @ 10...500 Hz
Shock, operating IEC 60068-2-27 (Test Ea, Unpackaged Shock)	30 g
Shock, nonoperating IEC 60068-2-27 (Test Ea, Unpackaged Shock)	50 g
Emissions	IEC 61000-6-4
ESD immunity IEC61000-4-2	6 kV contact discharges 8 kV air discharges
Radiated RF immunity IEC61000-4-3	10V/m with 1 kHz sine wave 80% AM from 80...2000 MHz 10V/m with 200 Hz 50% Pulse 100% AM at 900 MHz 10V/m with 200 Hz 50% Pulse 100% AM at 1890 MHz 3V/m with 1 kHz sine wave 80% AM from 2000...2700 MHz
EFT/B immunity IEC 61000-4-4	±4 kV @ 5 kHz on power ports ±2 kV @ 5 kHz on Ethernet ports
Surge transient immunity IEC 61000-4-5	±1 kV line-line (DM) and ±2 kV line-earth (CM) on power ports ±2 kV line-earth (CM) on Ethernet ports
Conducted RF immunity IEC 61000-4-6	10V rms with 1 kHz sine wave 80% AM from 150 kHz...80 MHz on power and Ethernet ports
Voltage variation IEC 61000-4-29	10 ms interruption on MOD power port

## Certifications - 5069-AEN2TR

Certifications <sup>(1)</sup>	5069-AEN2TR
c-UL-us	UL Listed Industrial Control Equipment, certified for US and Canada. See UL File E65584. UL Listed for Class I, Division 2 Group A,B,C,D Hazardous Locations, certified for U.S. and Canada. See UL File E194810.
CE	European Union 2014/30/EU EMC Directive, compliant with: <ul style="list-style-type: none"> <li>EN 61326-1; Meas./Control/Lab., Industrial Requirements</li> <li>EN 61000-6-2; Industrial Immunity</li> <li>EN 61000-6-4; Industrial Emissions</li> <li>EN 61131-2; Programmable Controllers (Clause 8, Zone A &amp; B)</li> </ul> European Union 2014/35/EU LVD, compliant with: <ul style="list-style-type: none"> <li>EN 61010-2-201; Control Equipment Safety Requirements</li> </ul> European Union 2011/65/EU RoHS, compliant with: <ul style="list-style-type: none"> <li>EN IEC 63000; Technical documentation</li> </ul>
RCM	Australian Radiocommunications Act, compliant with: EN 61000-6-4; Industrial Emissions
Ex	European Union 2014/34/EU ATEX Directive, compliant with: <ul style="list-style-type: none"> <li>EN 60079-15; Potentially Explosive Atmospheres, Protection "n"</li> <li>EN 60079-0; General Requirements</li> <li>II 3 G Ex nA IIC T4 Gc</li> <li>DEMKO 15 ATEX 1455X</li> </ul> When used at or below 125V AC
IECEx	IECEx System, compliant with: <ul style="list-style-type: none"> <li>IEC 60079-15; Potentially Explosive Atmospheres, Protection "n"</li> <li>IEC 60079-0; General Requirements</li> <li>II 3 G Ex nA IIC T4 Gc</li> <li>IECEx UL 15.0007X</li> </ul> When used at or below 125V AC
KC	Korean Registration of Broadcasting and Communications Equipment, compliant with: Article 58-2 of Radio Waves Act, Clause 3
EtherNet/IP	ODVA conformance tested to EtherNet/IP specifications

(1) When marked. See the Product Certification link at [rok.auto/certifications](http://rok.auto/certifications) for Declarations of Conformity, Certificates, and other certification details.

# 5069-ARM

## Address Reserve Module

Functional Block Diagram

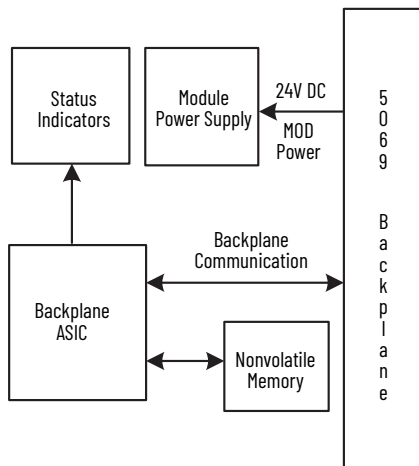

## Technical Specifications - 5069-ARM

Attribute	5069-ARM
Voltage and current ratings	
MOD power	45 mA @ 18...32V DC
MOD power (passthrough) <sup>(1)</sup>	9.55 A @ 18...32V DC
SA power (passthrough) <sup>(1)</sup> The module does not draw SA power current.	9.95 A @ 0...32V DC 9.975 A @ 0...240V AC, 47...63 Hz EX, 125V AC, max
Do not exceed 10 A MOD or SA power (Passthrough) current draw	
Power dissipation, max	1.0 W
Thermal dissipation, max	3.4 BTU/hr
Module keying	None
Indicators	1 green/red module status indicator
Dimensions (HxWxD), approx	144.57 x 22 x 105.42 mm (5.69 x 0.87 x 4.15 in.)
DIN rail	Compatible zinc-plated chromate-passivated steel DIN rail. You can use the EN50022 - 35 x 7.5 mm (1.38 x 0.30 in.) DIN rail.
Weight, approx	175 g (0.39 lb)

(1) Level of Mod or SA power current that passes through the module depends on the system configuration, such as, module slot location and the other module types that are used in the system. For more information, see the controller user manuals in [Additional Resources on page 63](#).

For **Certifications**, see [page 49](#).

For **Environmental Specifications**, see [page 50](#).

## 5069-FPD

## Field Potential Distributor

DC Wiring

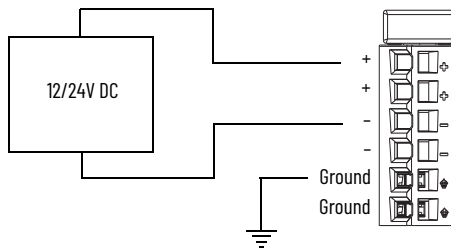

AC Wiring

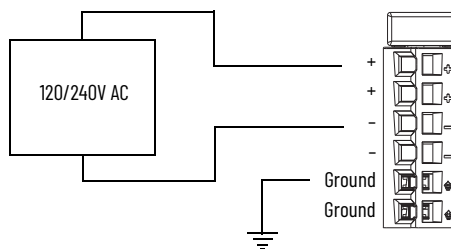

## Technical Specifications - 5069-FPD

Attribute	5069-FPD
Voltage and current ratings	
MOD power (passthrough) <sup>(1)</sup>	9.55 A @ 18...32V DC
SA power	10 mA @ 0...32V DC 25 mA @ 0...240V AC, 47...63 Hz EX, 125V AC, max
SA power (passthrough) <sup>(1)</sup>	9.99 A @ 0...32V DC 9.975 A @ 0...240V AC, 47...63 Hz EX, 125V AC, max
Do not exceed 10 A MOD or SA power (passthrough) current draw	
Power dissipation, max	4.0 W
Thermal dissipation, max	13.6 BTU/hr
Isolation voltage	250V (continuous), Basic Insulation Type Type tested at 1500V AC for 60 s
Module keying	None
Indicators	1 green module status indicator
Slot width	1
Dimensions (HxWxD), approx	144.57 x 22 x 105.42 mm (5.69 x 0.87 x 4.15 in.)
DIN rail	Compatible zinc-plated, chromate-passivated steel DIN rail. You can use the EN50022 - 35 x 7.5 mm (1.38 x 0.30 in.) DIN rail.
RTB	5069-RTB6-SCREW 5069-RTB6-SPRING
RTB torque (5069-RTB4-SCREW RTB only)	0.4 N•m (3.5 in•lb)
RTB keying	None
Wire category <sup>(2)</sup>	2 - on power ports
Wire size	
5069-RTB6-SPRING RTB	0.5...1.5 mm <sup>2</sup> (22...16 AWG) solid or stranded copper wire rated at 105 °C (221 °F), or greater, 2.9 mm (0.11 in.) max diameter including insulation, single wire connection only.
5069-RTB6-SCREW RTB	0.5...1.5 mm <sup>2</sup> (22...16 AWG) solid or stranded copper wire rated at 105 °C (221 °F), or greater, 3.5 mm (0.14 in.) max diameter including insulation, single wire connection only.
Insulation-stripping length	
5069-RTB6-SPRING RTB	10 mm (0.039 in.)
5069-RTB6-SCREW RTB	12 mm (0.47 in.)
Weight, approx	175 g (0.39 lb)

(1) Level of Mod or SA power current that passes through the module depends on the system configuration, such as, module slot location and the other module types that are used in the system. For more information, see the controller user manuals in [Additional Resources on page 63](#).

(2) Use this Conductor Category information to plan conductor routes. See the Industrial Automation Wiring and Grounding Guidelines, publication [1770-4.1](#).

For **Certifications**, see [page 49](#).

For **Environmental Specifications**, see [page 50](#).

# 5069-HSC2X0B4

## High-speed Counter Module

**Differential Encoder Wiring**

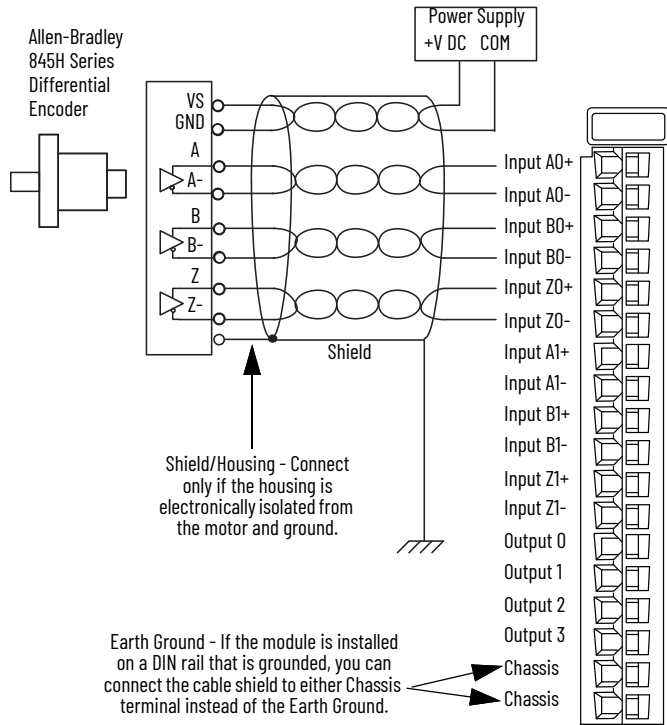

**Single-ended Encoder Wiring**

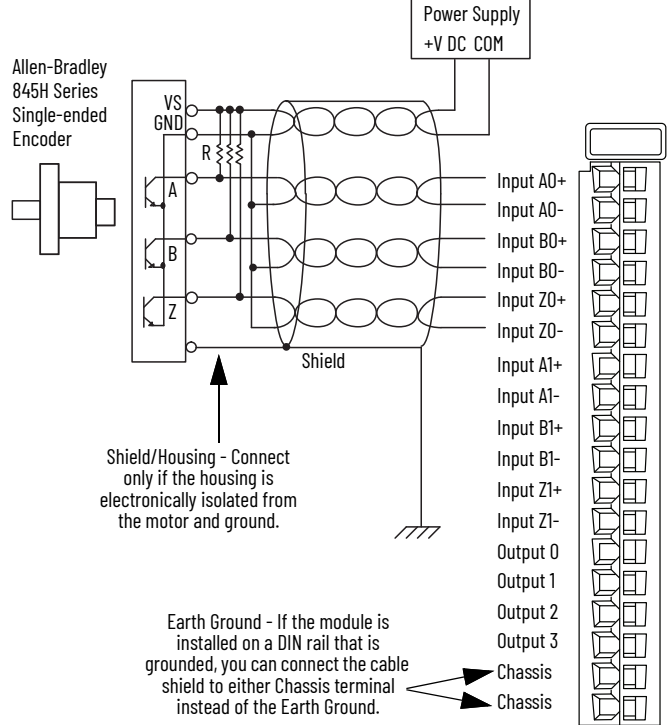

We recommend that you use twisted-pair, individually shielded cable with a maximum length of 300 m (1000 ft) when connecting a differential encoder. For more information on the cable type to use, see the encoder documentation.

<b>Channel Connections</b>	The diagram shows connections to channel 0. You are not restricted to using only that channel. You can connect to any channel or combination of channels as needed.
----------------------------	---

We recommend that you use twisted-pair, individually shielded cable with a maximum length of 300 m (1000 ft) when you connect a single-ended encoder. For more information on the cable type to use, see the encoder documentation.

<b>Channel Connections</b>	The diagram shows connections to input channel 0. You are not restricted to using only that channel. You can connect to any channel or combination of channels as needed.
----------------------------	---

**IMPORTANT:** External resistors, as indicated by the **R** location in the diagram, are required if they are not internal to the encoder. The pull-up resistor (R) value depends on the power supply value. The following table shows the maximum resistor values for typical supply voltages. To calculate the maximum resistor value, use the following formula:

$$R = \frac{VDC - Vmin}{Imin}$$

where:  
 R = Maximum pull-up resistor value  
 VDC = Power supply voltage  
 Vmin = 3.0V DC  
 Imin = 4.0 mA

Power Supply Voltage (V DC)	Pull-up Resistor Value (R), Max <sup>(1)</sup>
5	500 Ω
12	2250 Ω
24	5250 Ω

(1) Resistance values can change, depending on your application. The minimum resistor (R) value depends on the current-sinking capability of the encoder.



Discrete Input Device Wiring

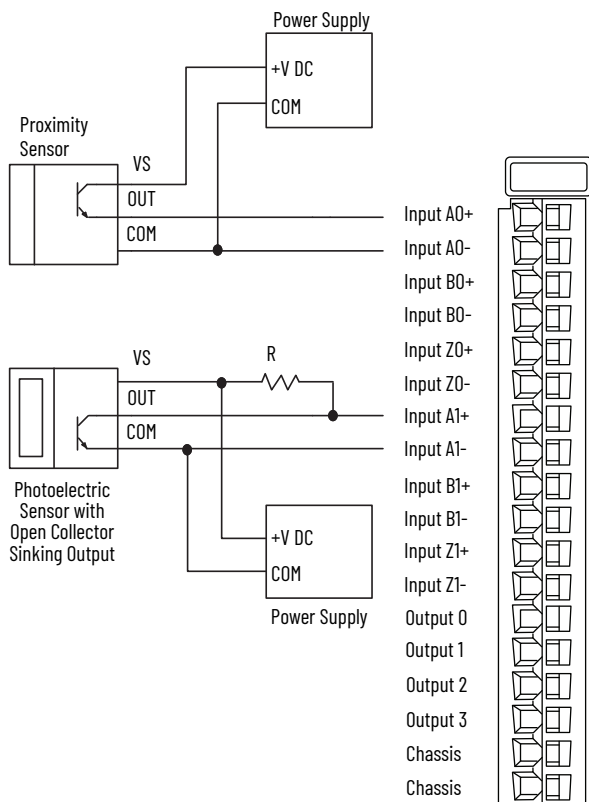

Discrete Output Device Wiring

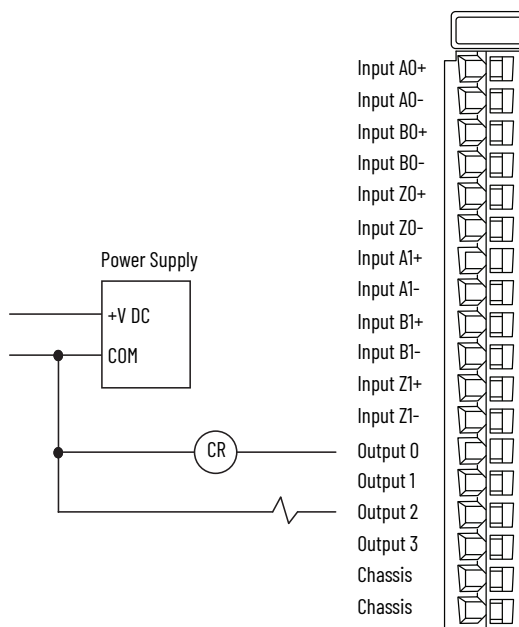

<b>Channel Connections</b>	The diagram shows connections to input channels 0 and 1. You are not restricted to using only those input channels. You can connect to any input channel or combination of input channels as needed.
----------------------------	--

**IMPORTANT:** External resistors, as indicated by the **R** location in the diagram, are required if they are not internal to the encoder. The pull-up resistor (R) value depends on the power supply value. The following table shows the maximum resistor values for typical supply voltages. To calculate the maximum resistor value, use the following formula:

$$R = \frac{VDC - Vmin}{Imin}$$

where:  
 R = Maximum pull-up resistor value  
 VDC = Power supply voltage  
 Vmin = 3.0V DC  
 Imin = 4.0 mA

Power Supply Voltage (V DC)	Pull-up Resistor Value (R), Max <sup>(1)</sup>
5	500 Ω
12	2250 Ω
24	5250 Ω

(1) Resistance values can change, depending on your application. The minimum resistor (R) value depends on the current-sinking capability of the encoder.

<b>Channel Connections</b>	The diagram shows connections to output channels 0 and 2. You are not restricted to using only those output channels. You can connect to any output channel or combination of output channels as needed.
<b>Surge Suppression</b>	The module has built-in suppression that is sufficient for most applications. For high-noise applications, we recommend that you use a 1N4004 diode reverse-wired across the load for transistor outputs switching 24V DC inductive loads. For additional details, see the Industrial Automation Wiring and Grounding Guidelines, publication <a href="#">1770-4.1</a> .
<b>SA Power</b>	Connections to an external power supply that provides SA power via the SA power RTB on one of the following: <ul style="list-style-type: none"> <li>• CompactLogix 5380 controller</li> <li>• Compact GuardLogix 5380 controller</li> <li>• CompactLogix 5480 controller</li> <li>• 5069-AENTR or 5069-AEN2TR EtherNet/IP Adapter</li> <li>• 5069-FPD field potential distributor</li> </ul>

- IMPORTANT**  
 Remember the following:
- You can only use DC SA power with the 5069-HSC2x0B4 module.
  - The 5069-HSC2x0B4 module outputs use a shared common. The outputs have a return through internal module circuitry to the SA (-) terminal on the SA power RTB. For more information, see page 6.
  - If you install modules in a Compact 5000 I/O system that use AC SA power and DC SA power, you must install them on separate SA power buses.
  - You use the 5069-FPD field potential distributor to establish a new SA power bus in a Compact 5000 I/O system. SA power buses are isolated from each other. To keep the modules on separate SA power buses, complete the following steps.
    1. Install the modules that use one type of SA power, for example AC, to the right of the adapter or controller, that is, the first SA power bus.
    2. Install the 5069-FPD field potential distributor to establish a second SA power bus.
    3. Install the modules that use the other type of SA power, for example DC, on the second SA power bus.

Functional Block Diagrams

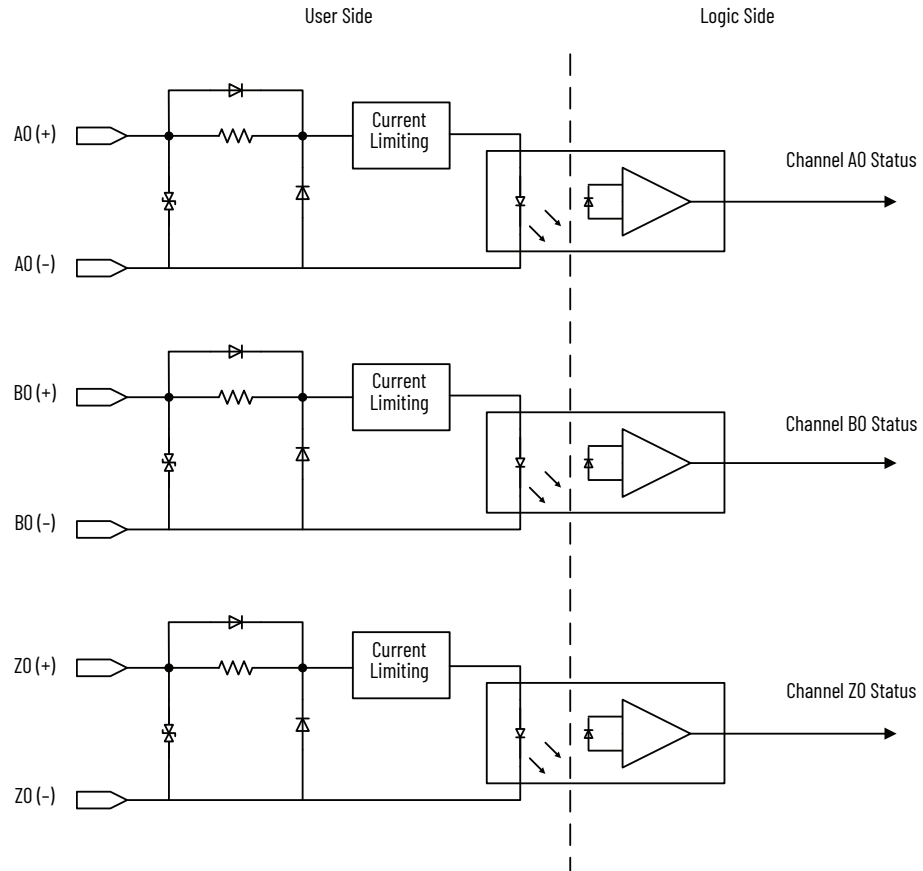

**Module Inputs**

This is a diagram for Counter 0. Counter 1 uses the same design. The modules only support a DC power source.

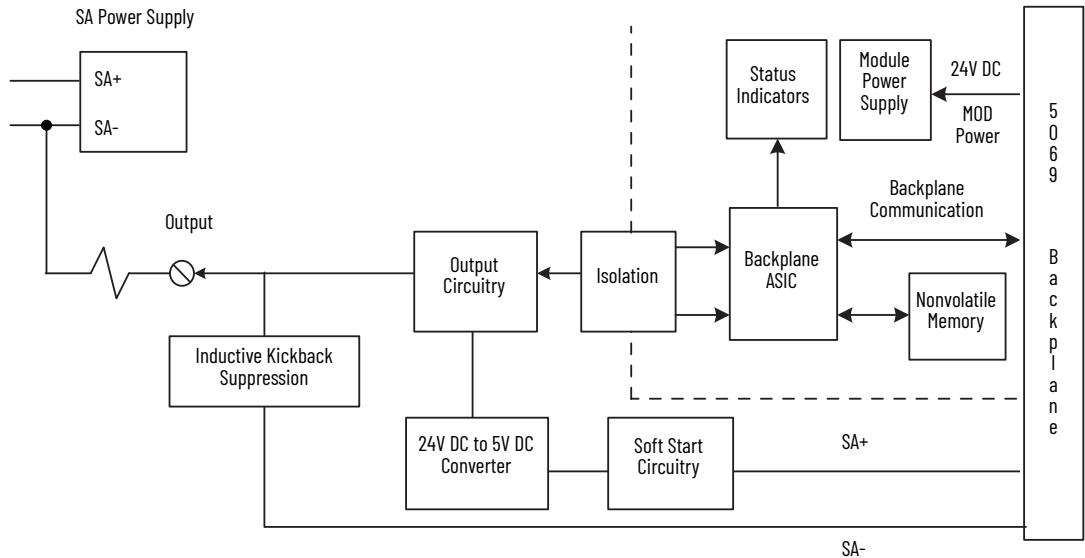

**Module Outputs**

Connections to external power supply that provides SA power. For more information, see [page 57](#).

## Technical Specifications - 5069-HSC2X0B4

Attribute	5069-HSC2X0B4
Inputs	2 quadrature (ABZ) differential inputs
Outputs	4 Channels (1 group of 4), sourcing
Voltage category	12/24V DC source
Voltage and current ratings	
Counter input ratings	4 mA @ 18...32V DC
MOD power	50 mA @ 18...32V DC
MOD power (passthrough) <sup>(1)</sup>	9.55 A @ 18...32V DC
SA power	3 A @ 18...32V DC
SA power (passthrough) <sup>(1)</sup>	9.95 A @ 10...32V DC
Do not exceed 10 A MOD or SA power (passthrough) current draw	
Power dissipation, max	3 W
Thermal dissipation, max	10.2 BTU/hr
Isolation voltage	300V (continuous), Basic Insulation Type No isolation between SA power and I/O ports No isolation between individual I/O ports Type tested at 1500V AC for 60 s
Module keying	Electronic keying via programming software
Indicators	1 green/red module status indicator 10 yellow/red I/O status indicator
Slot width	1
Dimensions (HxWxD), approx	144.57 x 22 x 105.42 mm (5.69 x 0.87 x 4.15 in.)
DIN rail	Compatible zinc-plated chromate-passivated steel DIN rail. • You can use the EN50022 - 35 x 7.5 mm (1.38 x 0.30 in.) DIN rail.
RTB	One of these RTB types. • 5069-RTB18-SPRING RTB • 5069-RTB18-SCREW RTB <b>IMPORTANT:</b> You must order RTBs separately. RTBs do not ship with Compact 5000 I/O modules. We recommend that you order only the RTB type that your system requires.
RTB keying	None
RTB torque (5069-RTB18-SCREW RTB only)	0.4 N•m (3.5 lb•in)
Wiring category <sup>(2)</sup>	2 - on shielded output ports 2 - on output power ports 2 - on shielded counter ports
Wire size	
5069-RTB18-SPRING RTB	0.5...1.5 mm <sup>2</sup> (22...16 AWG) solid or stranded shielded copper wire rated at 105 °C (221 °F), or greater, 2.9 mm (0.11 in.) max diameter including insulation
5069-RTB18-SCREW RTB	0.5...1.5 mm <sup>2</sup> (22...16 AWG) solid or stranded shielded copper wire rated at 105 °C (221 °F), or greater, 3.5 mm (0.14 in.) max diameter including insulation
Insulation-stripping length	
5069-RTB18-SPRING RTB	10 mm (0.39 in.)
5069-RTB18-SCREW RTB	12 mm (0.47 in.)
Weight, approx	175 g (0.39 lb)
Enclosure type	None (open-style)

## Technical Specifications - 5069-HSC2X0B4

Attribute	5069-HSC2X0B4
North American temp code	T4
UKEK/ATEX temp code	T4
IECEx temp code	T4
Input current, max	8 mA
On-state voltage, min	3V DC
On-state voltage, nom	24V DC
On-state voltage, max	32V DC
On-state voltage drop, max	< 0.3V DC
On-state current, min	4 mA
Off-state voltage, max	1.5V
Off-state current, max	1 mA
Output voltage range	10...32V DC
On-state output current, min	1 mA per channel 4 mA per module
Pulse width, min	125 ns
Pulse separation, min	100 ns
No load detection diagnostics	Yes (per channel diagnostics)
Output short circuit/overload/overtemp detection	Yes (per channel diagnostics)
Output short circuit/overload protection	Yes
Reverse voltage protection	32V DC
Overvoltage protection, max	36V (fuse protected)
Pilot duty	Yes (Make current electronically limited/protected @ 3.6 A)
Output control in fault state per point	• Hold last state • On • Off (default)
Output states in program mode per point	• Hold last state • On • Off (default)
Output states in fault mode per point	• Hold Last State • On • Off (default)
Duration of fault mode per point	• 1 s • 2 s • 5 s • 10 s • Forever (default)

- (1) Level of Mod or SA power current that passes through the module depends on the system configuration, such as, module slot location and the other module types that are used in the system. For more information, see the controller user manuals in [Additional Resources on page 63](#).
- (2) Use this Conductor Category information to plan conductor routes. See the Industrial Automation Wiring and Grounding Guidelines, publication [1770-4.1](#).

For **Certifications**, see [page 49](#).

For **Environmental Specifications**, see [page 50](#).

## 5069-SERIAL

### Serial Module

The Compact 5000 I/O serial module provides a network interface to RS-232, RS-422, and RS-485 devices.

Use the following information to wire the connector.

#### Communication Port Pins

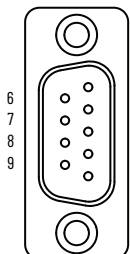

This image shows the pin layout on the 5069-serial module. See the following tables for pin descriptions, where:

– = Not Used

A = Changing signal level (Active/Inactive)

B = Fixing signal level (Active/Inactive)

#### RS-232C Pin Descriptions

Pin	RS-232C	Input (i)/Output (o) from 5069-SERIAL	Wiring	
			No Handshaking	Handshaking
1	Data Carrier Detect (DCD)	(i)	–	–
2	Receive Data (RXD)	(i)	A	A
3	Transmit Data (TXD)	(o)	A	A
4	Data Terminal Ready (DTR)	(o)	B	B
5	Common (COM)	–	A	A
6	Data Set Ready (DSR)	(i)	–	–
7	Request to Send (RTS)	(o)	B	A
8	Clear to Send (CTS)	(i)	–	A
9	–	–	–	–

#### RS-422 Pin Descriptions

Pin	RS-422	Input (i)/Output (o) from 5069-SERIAL	Wiring
1	–	–	–
2	Receive Data + (RXD+)	(i)	A
3	Transmit Data + (TXD+)	(o)	A
4	–	–	–
5	Common (COM)	–	A
6	–	–	–
7	Transmit Data - (TXD-)	(o)	A
8	Receive Data - (RXD-)	(i)	A
9	–	–	–

#### RS-485 Pin Descriptions

Pin	RS-485	Input (i)/Output (o) from 5069-SERIAL	Wiring
1	–	–	–
2	–	–	–
3	Transmit/Receive Data + (TRXD+)	(i/o)	A
4	–	–	–
5	Common (COM)	–	A
6	–	–	–
7	Transmit/Receive Data - (TRXD-)	(i/o)	A
8	–	–	–
9	–	–	–

**SA Power** The 5069-SERIAL module does not draw current from the SA power bus. Still, the module is a DC-type module, and you must install it on a DC SA power bus.

**IMPORTANT**

Remember the following:

- If you install modules in a Compact 5000 I/O system that use AC SA power and DC SA power, you must install them on separate SA power buses.
- You use the 5069-FPD field potential distributor to establish a new SA power bus in a Compact 5000 I/O system. SA power buses are isolated from each other. To keep the modules on separate SA power buses, complete the following steps.
  1. Install the modules that use one type of SA power, for example AC, to the right of the adapter or controller, that is, the first SA power bus.
  2. Install the 5069-FPD field potential distributor to establish a second SA power bus.
  3. Install the modules that use the other type of SA power, for example DC, on the second SA power bus.

#### RS-232 Connections

**IMPORTANT** If you wire the module incorrectly, the control between wiring and output signal can fail.

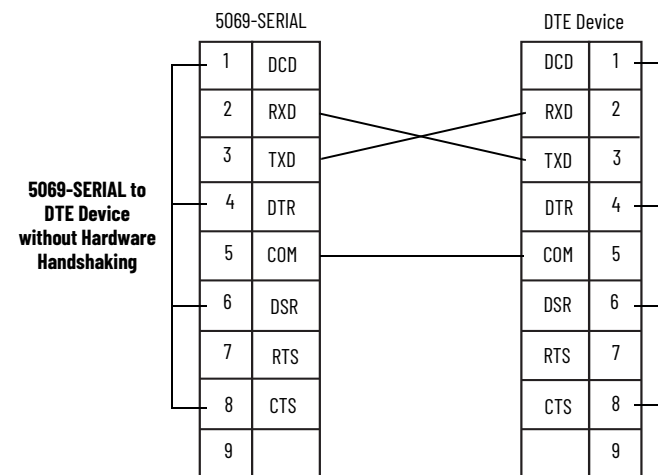

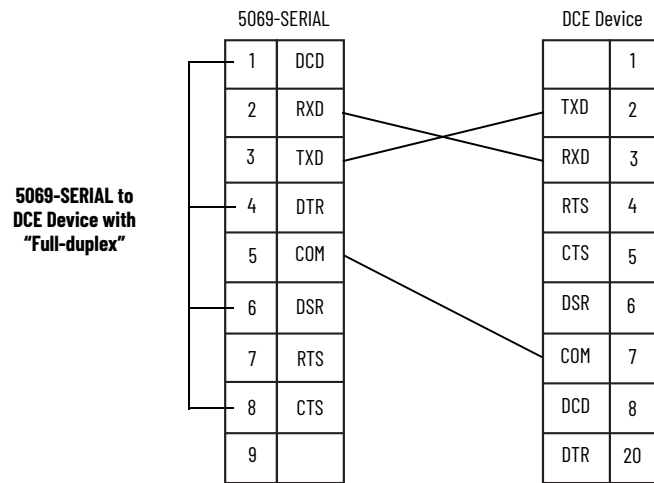
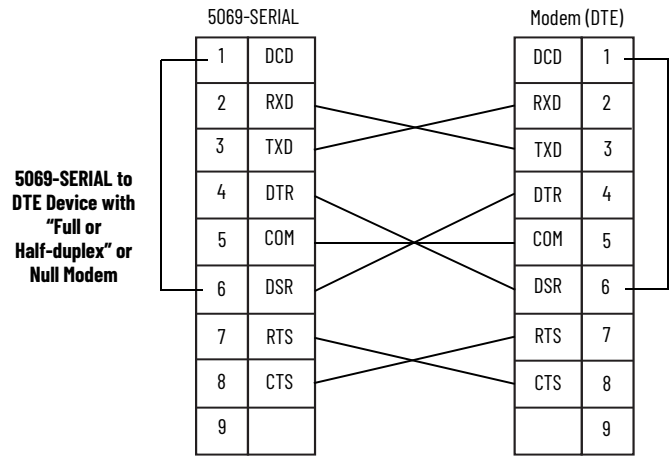
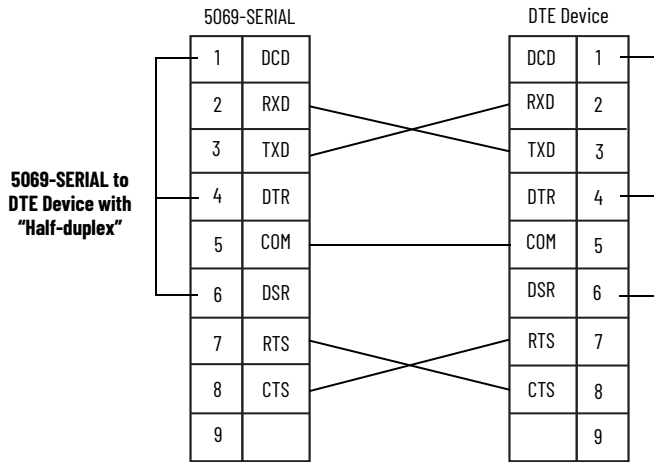

**RS-422 Connections**

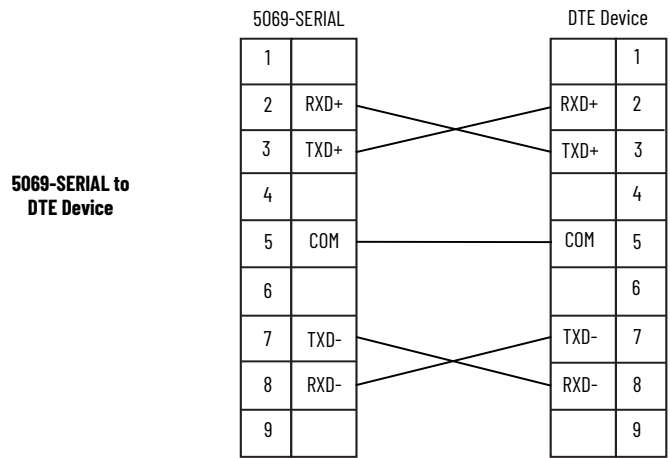

**IMPORTANT** Place the termination resistor between RXD+ and RXD- to implement this connection.

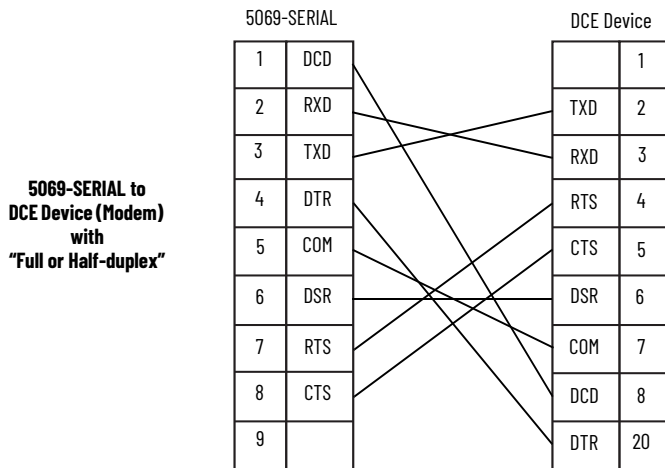

**RS-485 Connections**

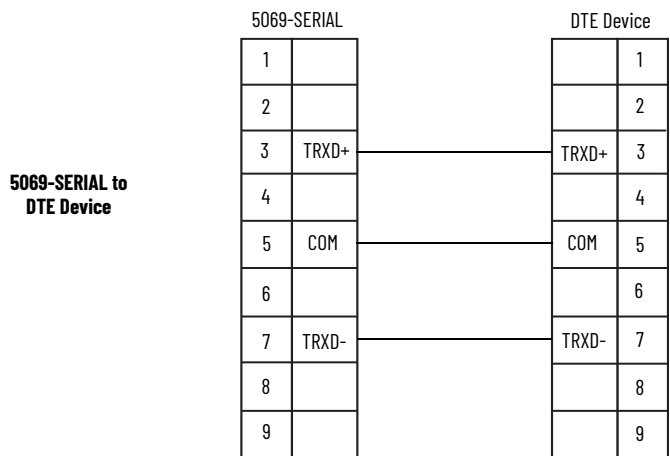

**IMPORTANT** Place the termination resistor between TRXD+ and TRXD- to implement this connection.

Functional Block Diagram

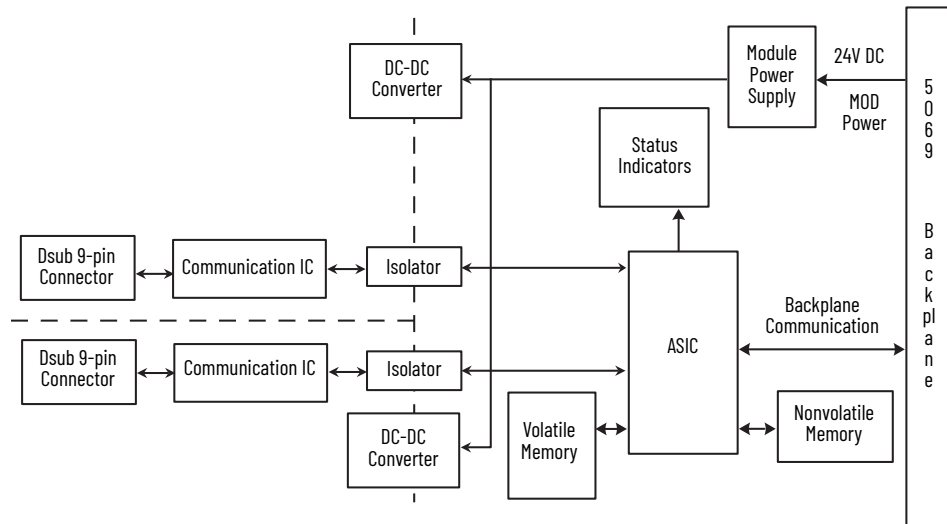

Technical Specifications - 5069-SERIAL

Attribute	5069-SERIAL
Operating modes	<ul style="list-style-type: none"> <li>• Generic ASCII</li> <li>• Modbus RTU</li> <li>• Modbus ASCII</li> <li>• DFI (local Channel 1 only)</li> <li>• DH-485 (local Channel 1 only)</li> </ul>
Inputs	<ul style="list-style-type: none"> <li>• 2 full-duplex (RS-232, RS-422)</li> <li>• 2 half-duplex (RS-485)</li> </ul>
Serial input voltage signal	<ul style="list-style-type: none"> <li>• 3...25V DC regarding signal ground (SG) 0, Asserted, ON, Space, Active</li> <li>• -3...-25V DC regarding signal ground (SG) 1, Deasserted, OFF, Mark, Inactive</li> </ul>
Voltage and current ratings	
MOD power	100 mA @ 18...32V DC
MOD power (passthrough) <sup>(1)</sup>	9.55 A @ 18...32V DC
SA power (passthrough) <sup>(1)</sup>	9.95 A @ 0...32V DC The module does not draw SA power current.
Do not exceed 10 A MOD or SA power (passthrough) current draw	
Power dissipation, max	2.8 W
Thermal dissipation, max	9.6 BTU/hr
Isolation voltage	250V (continuous), Basic Insulation Type, SA and MOD power to Backplane 250V (continuous), Basic Insulation Type, Backplane to Communication Channels 250V (continuous), Basic Insulation Type, Backplane to Chassis Ground 250V (continuous), Basic Insulation Type, Between Communication Channels 250V (continuous), Basic Insulation Type, SA to MOD power 250V (continuous), Basic Insulation Type, Communication Channels to Chassis Ground 250V (continuous), Basic Insulation Type, SA and MOD power to Chassis Ground 250V (continuous), Reinforced Insulation Type, SA and MOD power to Communication Channels Basic Insulation Type tested at 2100V DC for 60 s Reinforced Insulation Type tested at 4200V DC for 60 s

Technical Specifications - 5069-SERIAL

Attribute	5069-SERIAL
Transmit transaction ID	0...255
Handshaking	RTS/CTS hardware handshake always enabled. RTS/CTS can be user-controlled.
Module keying	None
Indicators	1 green/red module status indicator 1 transmit data (TXD) and 1 receive data (RXD) yellow/red status indicator per channel
Slot width	1
Dimensions (HxWxD), approx	137.85 x 22 x 105.42 mm (5.43 x 0.87 x 4.15 in.)
DIN rail	Compatible zinc-plated chromate-passivated steel DIN rail. You can use the EN50022 - 35 x 7.5 mm (1.38 x 0.30 in.) DIN rail.
RTB keying	None
Serial port connectors	Two DB-9 male with pins
Wire category <sup>(2)(3)</sup>	2 - power ports 2 - communication ports
Weight, approx	175 g (0.39 lb.)
Corrosion resistance classification	ISA S71.04 G2

- (1) Level of Mod or SA power current that passes through the module depends on the system configuration, such as, module slot location and the other module types that are used in the system. For more information, see the controller user manuals in [Additional Resources on page 63](#).
- (2) Use this Conductor Category information to plan conductor routes. See the Industrial Automation Wiring and Grounding Guidelines, publication [1770-4.1](#).
- (3) Use this Conductor Category information to plan conductor routes as described in the appropriate System Level Installation Manual.

For **Certifications**, see [page 49](#).

For **Environmental Specifications**, see [page 50](#).

## Additional Resources

These documents contain additional information concerning related products from Rockwell Automation. You can view or download publications at [rok.auto/literature](http://rok.auto/literature).

Resource	Description
Compact 5000 I/O Digital Modules User Manual, publication <a href="#">5069-UM004</a>	Describes how to configure and operate Compact 5000™ I/O digital modules.
Compact 5000 I/O Analog Modules User Manual, publication <a href="#">5069-UM005</a>	Describes how to configure and operate Compact 5000 I/O analog modules.
Compact 5000 I/O High-speed Counter Module User Manual, publication <a href="#">5069-UM006</a>	Describes how to configure and operate the Compact 5000 I/O high-speed counter module.
Compact 5000 I/O Serial Module User Manual, publication <a href="#">5069-UM003</a>	Describes how to configure and operate Compact 5000 serial modules.
CompactLogix 5380 and Compact GuardLogix 5380 Controllers User Manual, publication <a href="#">5069-UM001</a>	Describes how to configure and operate CompactLogix™ 5380 and Compact GuardLogix® 5380 controllers.
CompactLogix 5480 Controllers User Manual, publication <a href="#">5069-UM002</a>	Describes how to configure and operate CompactLogix 5480 controllers.
Compact 5000 EtherNet/IP Adapters User Manual, publication <a href="#">5069-UM007</a>	Describes how to configure and operate the Compact 5000 I/O EtherNet/IP™ adapters.
Industrial Automation Wiring and Grounding Guidelines, publication <a href="#">1770-4.1</a>	Provides general guidelines for installing a Rockwell Automation industrial system.
Product Certifications website, <a href="http://rok.auto/certifications">rok.auto/certifications</a>	Provides declarations of conformity, certificates, and other certification details.

# Rockwell Automation Support

Use these resources to access support information.

<b>Technical Support Center</b>	Find help with how-to videos, FAQs, chat, user forums, Knowledgebase, and product notification updates.	<a href="http://rok.auto/support">rok.auto/support</a>
<b>Local Technical Support Phone Numbers</b>	Locate the telephone number for your country.	<a href="http://rok.auto/phonesupport">rok.auto/phonesupport</a>
<b>Technical Documentation Center</b>	Quickly access and download technical specifications, installation instructions, and user manuals.	<a href="http://rok.auto/techdocs">rok.auto/techdocs</a>
<b>Literature Library</b>	Find installation instructions, manuals, brochures, and technical data publications.	<a href="http://rok.auto/literature">rok.auto/literature</a>
<b>Product Compatibility and Download Center (PCDC)</b>	Download firmware, associated files (such as AOP, EDS, and DTM), and access product release notes.	<a href="http://rok.auto/pcdc">rok.auto/pcdc</a>

## Documentation Feedback

Your comments help us serve your documentation needs better. If you have any suggestions on how to improve our content, complete the form at [rok.auto/docfeedback](http://rok.auto/docfeedback).





Allen-Bradley, Compact 5000, CompactLogix, expanding human possibility, GuardLogix, Logix 5000, Rockwell Automation, Rockwell Software, and Studio 5000 Logix Designer are trademarks of Rockwell Automation, Inc.

CIP Sync and EtherNet/IP are trademarks of ODVA, Inc.

Trademarks not belonging to Rockwell Automation are property of their respective companies.

Rockwell Automation maintains current product environmental compliance information on its website at [rok.auto/pec](http://rok.auto/pec).

Rockwell Otomasyon Ticaret A.Ş. Kar Plaza İş Merkezi E Blok Kat:6 34752, İçerenköy, İstanbul, Tel: +90 (216) 5698400 EEE Yönetmeliğine Uygundur

Connect with us.    

[rockwellautomation.com](http://rockwellautomation.com) — expanding **human possibility**<sup>®</sup>

AMERICAS: Rockwell Automation, 1201 South Second Street, Milwaukee, WI 53204-2496 USA, Tel: (1) 414.382.2000, Fax: (1) 414.382.4444

EUROPE/MIDDLE EAST/AFRICA: Rockwell Automation NV, Pegasus Park, De Kleetlaan 12a, 1831 Diegem, Belgium, Tel: (32) 2663 0600, Fax: (32) 2 663 0640

ASIA PACIFIC: Rockwell Automation SEA Pte Ltd, 2 Corporation Road, #04-05, Main Lobby, Corporation Place, Singapore 618494, Tel: (65) 6510 6608, FAX: (65) 6510 6699

UNITED KINGDOM: Rockwell Automation Ltd., Pitfield, Kiln Farm, Milton Keynes, MK11 3DR, United Kingdom, Tel: (44)(1908) 838-800, Fax: (44)(1908) 261-917

Publication 5069-TD001N-EN-P - November 2023

Supersedes Publication 5069-TD001M-EN-P - April 2022

Copyright © 2023 Rockwell Automation, Inc. All rights reserved. Printed in the U.S.A.